

## Product Description

- ◆ Load Current: 25A, 40A, 60A, 80A, 100A, 125A
- ◆ SCR Output
- ◆ Control Model: 0-5VDC, 0-10VDC, 4-20mA, PWM
- ◆ Phase-Shift Control Output
- ◆ LED Indicator
- ◆ RoHS Compliant



## Product Selection

<b>KYR</b>	<b>P</b>	<b>240</b>	<b>L</b>	<b>25</b>	<b>P</b>	<b>(XXX)</b>
KYR Series	Output Type P: Phase-Shift Control Output	Load Voltage 240: 176-280VAC 480: 200-530VAC	Control Mode L: 0-5VDC H: 0-10VDC I: 4-20mA W: PWM	Load Current 25: 25Amp 40: 40Amp 60: 60Amp 80: 80Amp 100: 100Amp 125: 125Amp	P: IP20 Safety Cover	Customized Code

### Load Voltage Calculation Formula

Control Mode	Load Voltage <sup>(1)</sup>
L: 0-5VDC	$U_{LOAD} = U_{AC} \times V_{CONTROL} / 5$
H: 0-10VDC	$U_{LOAD} = U_{AC} \times V_{CONTROL} / 10$
I: 4-20mA	$U_{LOAD} = U_{AC} \times (I_{CON} - 4) / 16$
W: PWM(@100ms cycle)	$U_{LOAD} = U_{AC} \times \text{占空比}$

Note: (1)  $U_{LOAD}$  indicates the voltage at both ends of the load, and  $U_{AC}$  indicates the power grid voltage,  $V_{CONTROL}$  indicates the control voltage,  $I_{CON}$  indicates the control current.

## Technical Specifications

Input Specifications (Ta=25°C)	Condition	Symbol	Model	Min	Typ	Max	Unit
Auxiliary Power Supply Voltage				10	12/24	32	VDC
Auxiliary Power Supply Current(Typ)						25	mA
Voltage Control	Condition	Symbol	Model	Min	Typ	Max	Unit
Control Voltage		$U_c$	L	0		5	VDC
			H	0		10	VDC
Turn-on Voltage		$U_{c\ on}$	L			0.15	VDC
			H			0.25	VDC
Turn-off Voltage		$U_{c\ off}$	L	0.05			VDC
			H	0.1			VDC
Input Impedance			L		30		kΩ
			H		60		kΩ
Current Control <sup>(2)</sup>	Condition	Symbol	Model	Min	Typ	Max	Unit
Control Current		$I_c$		4		20	mA
Turn-on Current		$I_{c\ on}$				4.9	mA
Turn-off Current		$I_{c\ off}$		4.1			mA
Input Impedance	@20mA				290		Ω

PWM Control <sup>(3)</sup>	Condition	Symbol	Model	Min	Typ	Max	Unit
Period					100		ms
Amplitude				10	12/24	32	VDC
Control Current		$I_c$				15	mA

Note: (2) Current control type, the drive voltage should be more than 6V.  
(3) Control mode such as other cycles of PWM requirements, can be customized.

Output Specifications (Ta=25°C)	Condition	Symbol	Model	Min	Typ	Max	Unit
Load Voltage		$U_e$	240	176		280	VDC
			480	200		530	VDC
Load Current		$I_e$	25A	0.1		25	A
			40A	0.1		40	A
			60A	0.1		60	A
			80A	0.1		80	A
			100A	0.1		100	A
			125A	0.1		125	A
Off-State Leakage Current	@ Rated Load Voltage	$I_{lk}$			1.6	5	mA
	@220VAC/50Hz	$I_{lk}$					mA
Operational Frequency		f		47	50/60	63	Hz
Output Power				0		99	%
Transient Overvoltage		$U_p$	240		600		Vpk
			480		1200		Vpk
Non-repetitive Surge Current	@10ms	$I_{TSM}$	25A		250		Apk
			40A		500		Apk
			60A		700		Apk
			80A		800		Apk
			100A		1000		Apk
			125A		2250		Apk
Maximum $I^2t$ for Fusing	@10ms	$I^2t$	25A		312		A <sup>2</sup> s
			40A		1250		A <sup>2</sup> s
			60A		2450		A <sup>2</sup> s
			80A		3250		A <sup>2</sup> s
			100A		5000		A <sup>2</sup> s
			125A		25000		A <sup>2</sup> s
Minimum Off-State dv/dt		dv/dt			500	V/ $\mu$ s	

General Specifications (Ta=25°C)	Condition	Symbol	Model	Min	Typ	Max	Unit
Dielectric Strength	50/60Hz, Input/Output	$V_{ISO}$			4000		Vrms
	50/60Hz, Input,Output/Base				2500		Vrms
Insulation Resistance	@500VDC	$R_{ISO}$			1000		M $\Omega$
Operating Temperature		$T_{OPR}$		-40		+70	°C
Storage Temperature		$T_{SPR}$		-40		+100	°C
Wight					120		g
LED Indication			Green	When the product is connected, LED lights up			

## Applications

Temperature chamber, plastic machinery, incubator, dimmer, solar panel welding machine, and etc.

Outline Dimensions

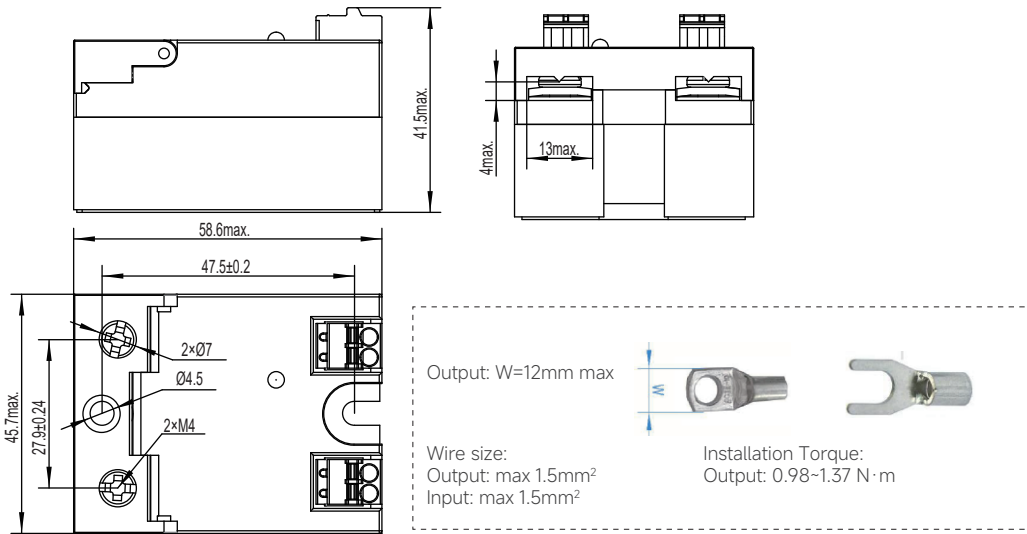

Voltage Control, PWM Control

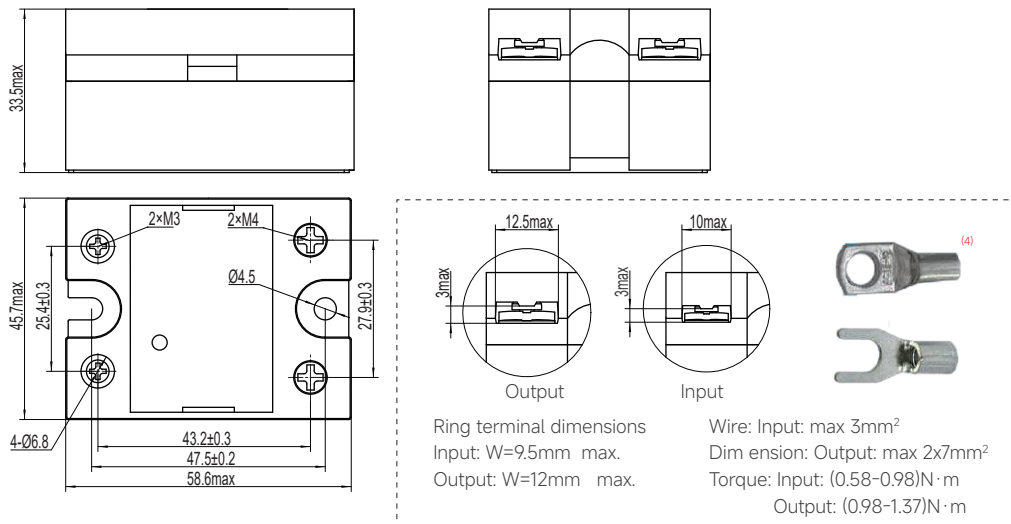

Current Control

Wiring Diagram

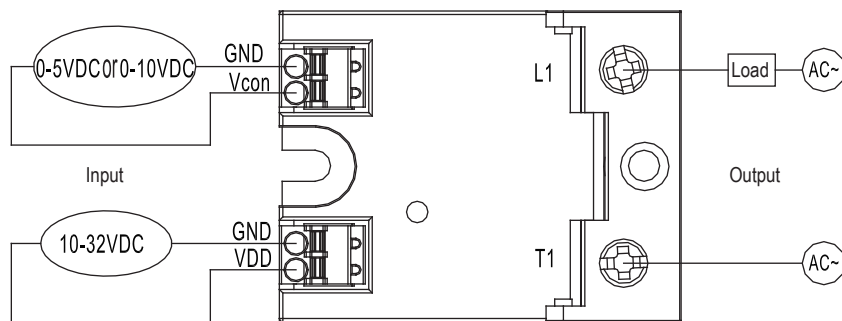

Voltage Control (5)

Note: (5) The auxiliary power supply GND and the input control GND should be connected internally to the earth ground; if the external control signal and the power supply are not connected together to the earth ground, then both should be connected to each GND respectively.

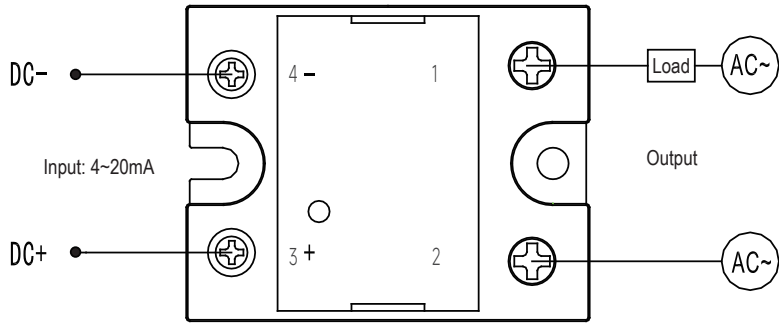

Current Control

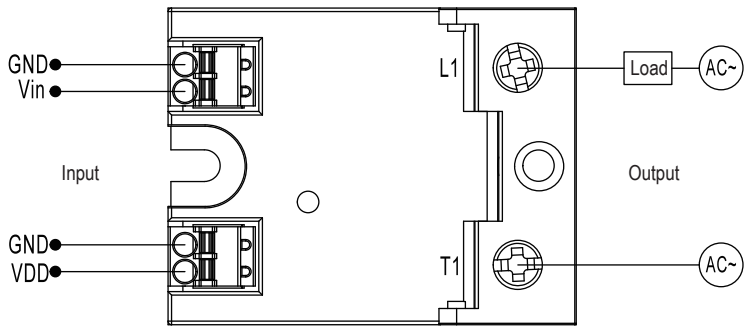

PWM Control

VDD: connects to the positive terminal of the auxiliary power supply ranging from 10 to 32VDC  
 Vin: Connect to PWM output positive terminal  
 GND: The auxiliary power supply GND and the control signal GND are shorted in common ground, for example, the external control signal and the power supply are not in common ground. If yes, connect the GND signals of the two devices respectively.

**Output / Proportional Control Features**

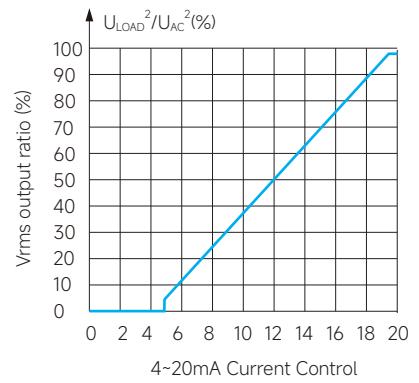
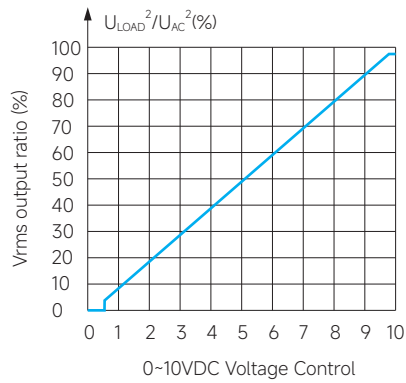
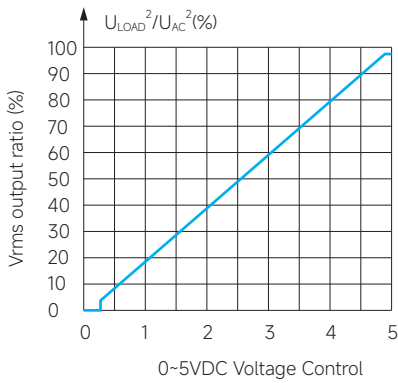

Load output power 25% (@ 25% control analog quantity)



Load output power 50% (@ 50% control analog quantity)



Load output power 75% (@ 75% control analog quantity)

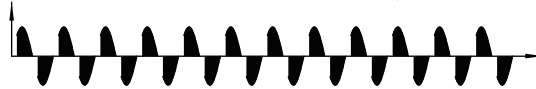

Load output power 100% (@ 100% control analog quantity)



Analog quantity and waveform diagram of voltage at both ends of the load

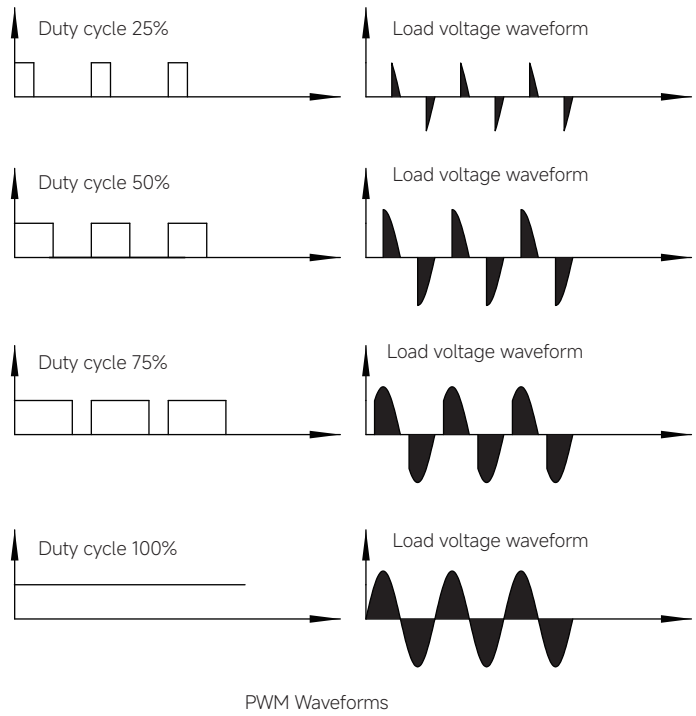
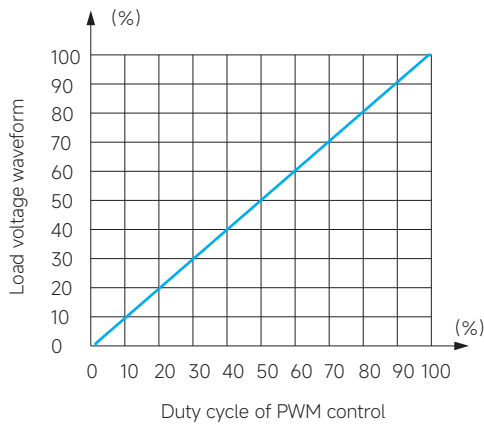

**Thermal Derating Curve**

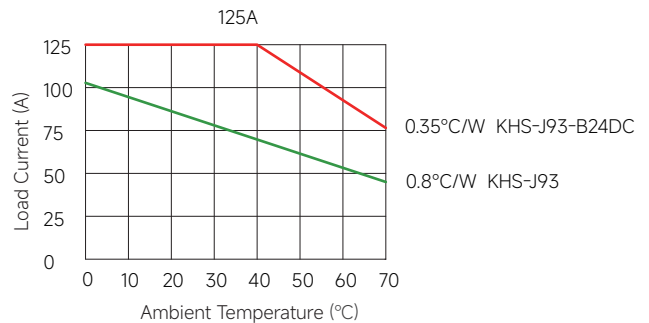
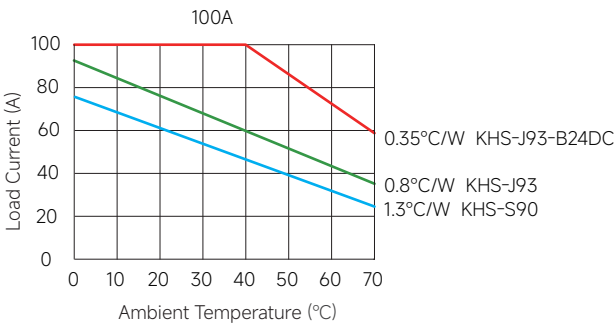
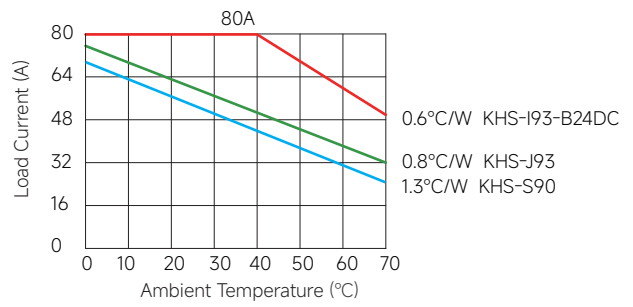
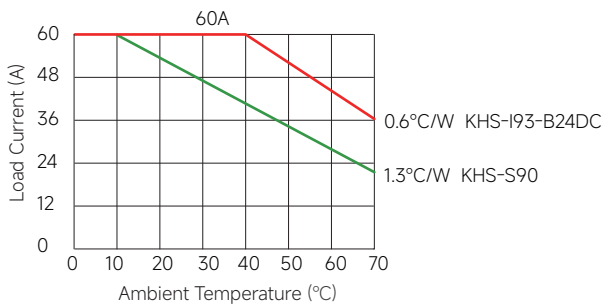
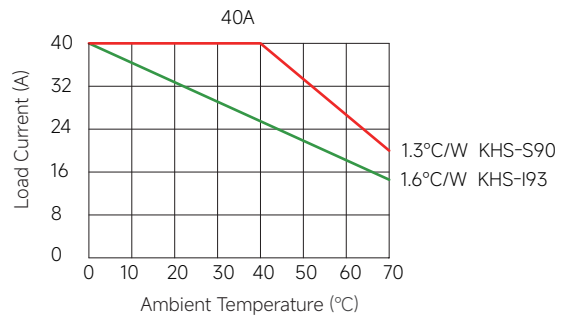
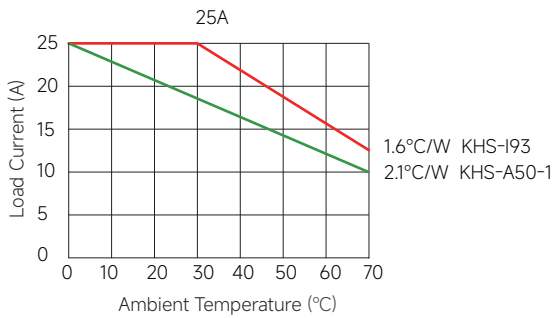

The above temperature curve is configured with radiator models as follows:

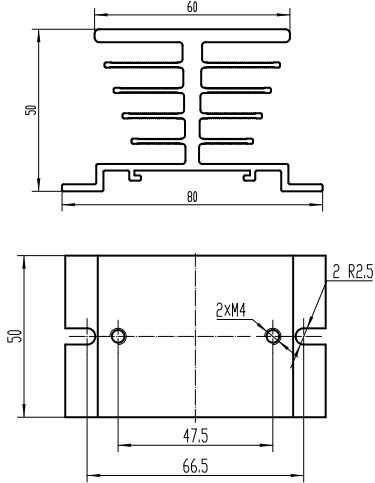

KHS-A50-1

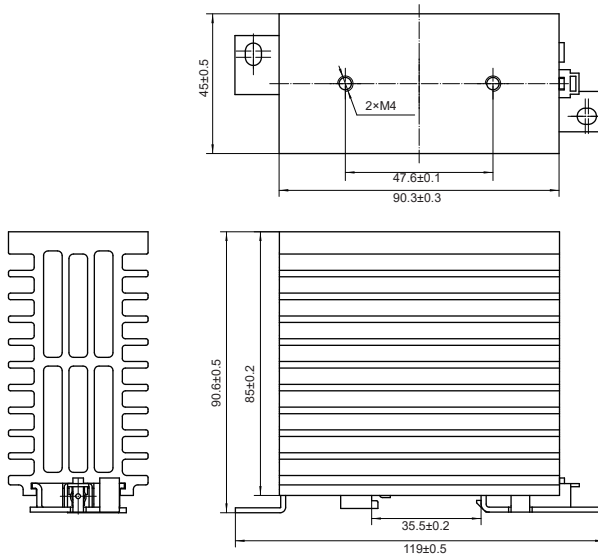

KHS-S90

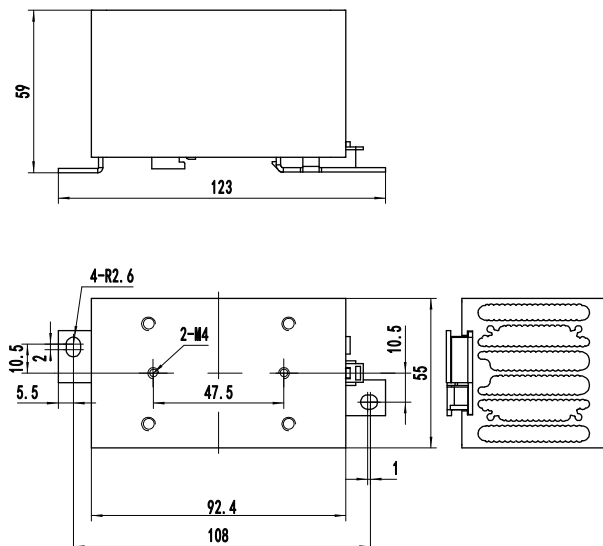

KHS-193

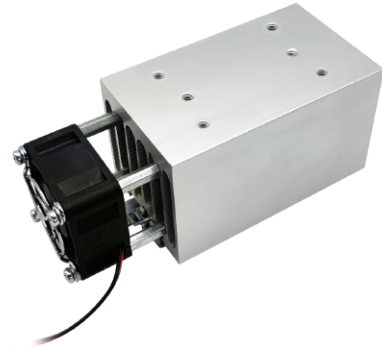
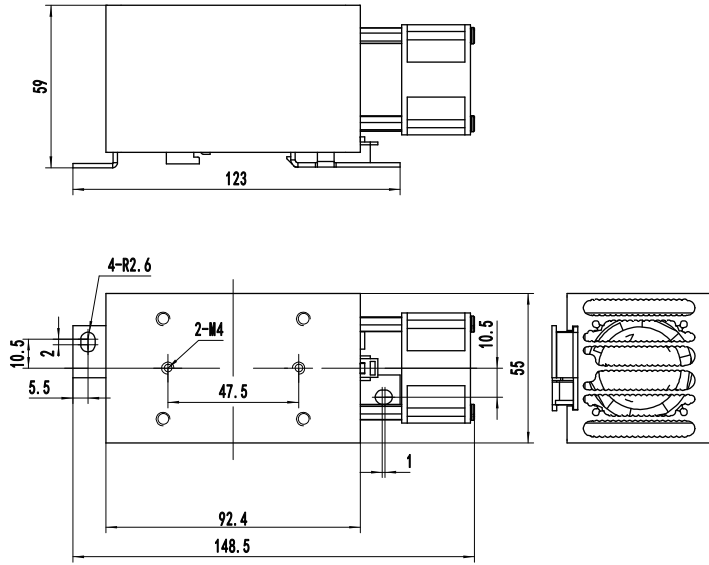

KHS-I93-B24DC

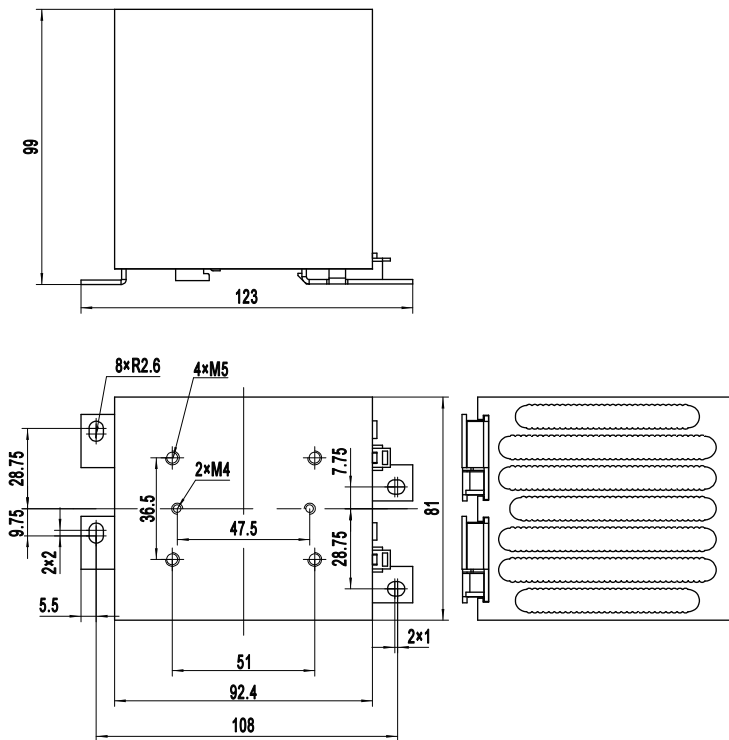

KHS-J93

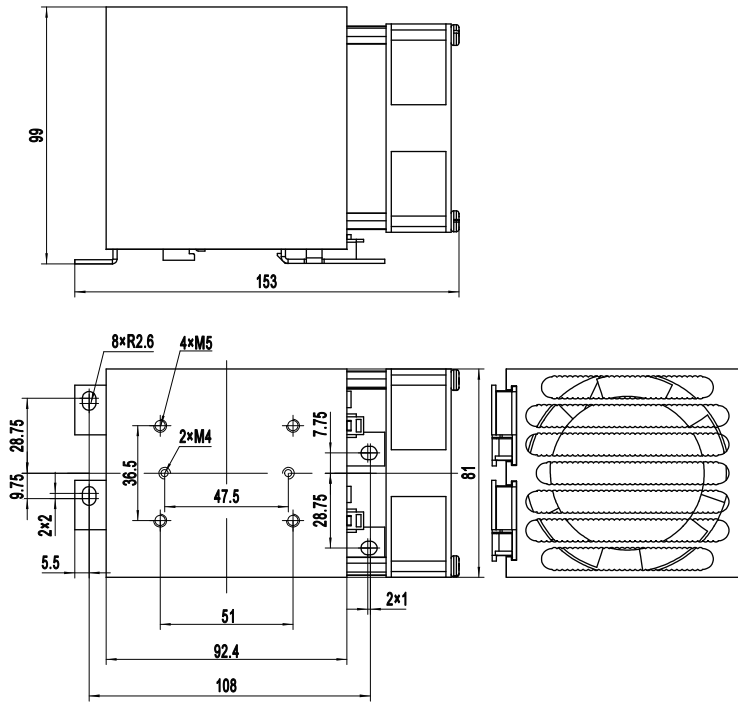

KHS-J93-B24DC

## General Notes

1. When the operation temperature is above 25°C, please consider the derating as per the Thermal Derating Curve.
2. The relay terminal should ensure reliable connection. Otherwise, it may cause the overheating of relay and lead to the damage. The recommended installation torque for screw fast connection terminals is 0.5N·m, the recommended installation torque for M3 terminals is (0.58 ~ 0.98) N·m, and the recommended installation torque for M4 terminals is (0.98 ~ 1.37) N·m.
3. Please ensure reliable grounding when using the SSR.

## ! Warnings

1. The product may be hot, allow the product to cool before touching.
2. Disconnect all power before installing or working with this equipment.
3. Verify all connections and replace all covers before turning on power.