

Product Description

- ◆ Control Input: 0~5VDC, 0~10VDC, 4~20mA
- ◆ Phase Angel Control Output or Cycle
- ◆ SCR Output
- ◆ IP20
- ◆ Built in RC Protection Circuit
- ◆ Panel Mount or 35mm Din Rail Mount
- ◆ Over-temperature Protection
- ◆ SCR Fault Detection Function
- ◆ Load Disconnection Detection Function
- ◆ Phase-lack Detection Function

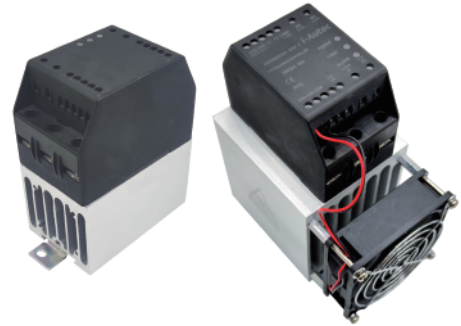

Product Selection

KRE	600	W	25	P	-D	E	M
KRE Series	Load Voltage 380: 200~440VAC 600: 400~660VAC	Control Mode W:4~20mA 0~5VDC 0~10VDC	Load Current 25: 25Amp 40: 40Amp 60: 60Amp 80: 80Amp	Propotional Output: P: Phase angle switching C: Full cycle switching	APS D:24VDC	Enable Function (Optional) E: Positive Triggered Enable Function None: No Enable Function	Characteristic Functions (Optional) M: Over-temperature Protection SCR Fault Detection Function Load Disconnection Detection Function Phase-lack Detection Function EMR Alarm Output
F	-3						
F: 24VDC Fan Blank: No Fan	3: Three Phase 3-leg Control 2: Three Phase 2-leg Control ⁽¹⁾						

Note: (1) 3 Phase 2-leg Control product output type only cycle output.

Available Part Numbers

Control Mode	25A	40A	60A	80A
W:4~20mA 0~5VDC 0~10VDC	KRE380W25P-D-3	KRE380W40P-DF-3	KRE380W60P-DF-3	KRE380W80P-DF-3
	KRE380W25P-DM-3	KRE380W40P-DMF-3	KRE380W60P-DMF-3	KRE380W80P-DMF-3
	KRE600W25P-D-3	KRE600W40P-DF-3	KRE600W60P-DF-3	KRE600W80P-DF-3
	KRE600W25P-DM-3	KRE600W40P-DMF-3	KRE600W60P-DMF-3	KRE600W80P-DMF-3
	KRE380W25C-D-3	KRE380W40C-DF-3	KRE380W60C-DF-3	KRE380W80C-DF-3
	KRE380W25C-DM-3	KRE380W40C-DMF-3	KRE380W60C-DMF-3	KRE380W80C-DMF-3
	KRE600W25C-D-3	KRE600W40C-DF-3	KRE600W60C-DF-3	KRE600W80C-DF-3
	KRE600W25C-DM-3	KRE600W40C-DMF-3	KRE600W60C-DMF-3	KRE600W80C-DMF-3
	KRE380W25C-D-2	KRE380W40C-DF-2	KRE380W60C-DF-2	KRE380W80C-DF-2
	KRE380W25C-DM-2	KRE380W40C-DMF-2	KRE380W60C-DMF-2	KRE380W80C-DMF-2
	KRE600W25C-D-2	KRE600W40C-DF-2	KRE600W60C-DF-2	KRE600W80C-DF-2
	KRE600W25C-DM-2	KRE600W40C-DMF-2	KRE600W60C-DMF-2	KRE600W80C-DMF-2

产品型号	Control Mode	Output Mode ⁽²⁾
KRE Series	4~20mA	$U_{LOAD}^2 = U_{AC}^2 \times V_{CONTROL} / 10$
	0~5VDC	$U_{LOAD}^2 = U_{AC}^2 \times V_{CONTROL} / 5$
	0~10VDC	$U_{LOAD}^2 = U_{AC}^2 \times (I_{CON} - 4) / 16$

Note: (2) U_{LOAD} indicates the voltage at both ends of the load, U_{AC} indicates the power grid voltage, I_{CON} indicates the control current, $V_{CONTROL}$ indicates the control voltage.

Technical Specifications

Input Specifications (Ta=25°C)			
Voltage Range of APS			21.6~26.4VDC
Normal working condition APS Current (typical value)	Suffix with F series		≤240mA@24VDC
	Suffix without F series		≤60mA@24VDC
Under fault condition APS Current (typical value)	Suffix with M series		≤50mA@24VDC
	Suffix without M series		≤30mA@24VDC
Control Signal Parameters	Voltage Control	Control Voltage Range	0~5VDC 0~10VDC
		Turn-on Voltage (0~10VDC)	0.4VDC Max.
		Turn-on Voltage (0~5VDC)	0.2VDC Max.
		Turn-off Voltage (0~10VDC)	0.1VDC Min.
		Turn-off Voltage (0~5VDC)	0.05VDC Min.
	Current Control	Input Resistance (0~10VDC)	25kΩ Typ.
		Input Resistance (0~5VDC)	49kΩ Typ.
		Control Current Range	4~20mA
		Turn-on Current	4.6mA Max.
		Turn-off Current	3.8mA Max.
		Input Resistance	200Ω Typ.

Output Specifications (Ta=25°C)		
Load Voltage Range	380	200~440VAC
	600	400~660VAC
Maximum Surge Current (@10ms)	25A	400A
	40A	500A
	60A	700A
	80A	1100A
Maximum I ² t for Fusing (@10ms)	25A	800A ² s
	40A	1250A ² s
	60A	2450A ² s
	80A	6050A ² s
Transient Overvoltage		1200Vpk ⁽³⁾
Output Power		0~99%
Operational Frequency Range		47~63Hz
Maximum Off-State Leakage Current (@220VAC/50Hz)		5mA (@220VAC/50Hz)
Minimum Off-State dv/dt (dv/dt)		500V/us

Note: (3) For products with a maximum transient voltage of 1600Vpk, please contact the manufacturer for customization.

General Specifications (Ta=25°C)		
EMR Alarm Node Parameters	Output Type	A set of normally open electromagnetic relays
	Dielectric Withstand (Between Disconnecting Contacts)	1000VAC
	Contact load (Resistance)	2A@250VAC/30VDC
Dielectric Strength (50/60Hz)	Input/Output	4000Vrms
	Input,Output/Base	4000Vrms
Ambient Temperature Range		-30°C ~ +80°C
Storage Temperature Range		-30°C ~ +100°C
Weight (Typical)	KRE...25... Series	650g
	KRE...(40/60/80)...F... Series	1160g
LED Indication	POWER	Power Supply Indicator
	LOAD	Connection Indicator
	ALARM	Fault Indicator

Function Introduction	
Over-temperature Protection ⁽⁴⁾	When the product is working, the temperature of the product is monitored in real time. When the set temperature value is exceeded by 100 °C (typical value), the output of the product will be cut off. At the same time, the fault indicator light is on and the output is normally open and the alarm contacts (NO, COM) are closed. It is necessary to wait for the temperature of the product to drop below the set value of 60 °C (typical value) before the product can return to normal working state on its own.
SCR Fault Detection	When no control signal is applied to the product, if the SCR short circuit is found, the fault indicator light is on and the output of the alarm contacts (NO, COM) will be closed.
Load Disconnection Detection	When no control signal is applied to the product, if load disconnection is found, SSR output will be cut off. At the same time, the fault indicator will be lighted and the output of the alarm contacts (NO, COM) will be closed.
Phase-lack Detection	When the phase-lack failure happens in 3 phase voltage, the relay will automatically cut off the output with the fault indicator lighted and the output of the alarm contacts (NO, COM) will be closed.

Note: (4) if you need to change the threshold value of overtemperature protection temperature setting and recovery temperature setting in the overtemperature protection function, you can contact the manufacturer to customize.

Outline Dimensions

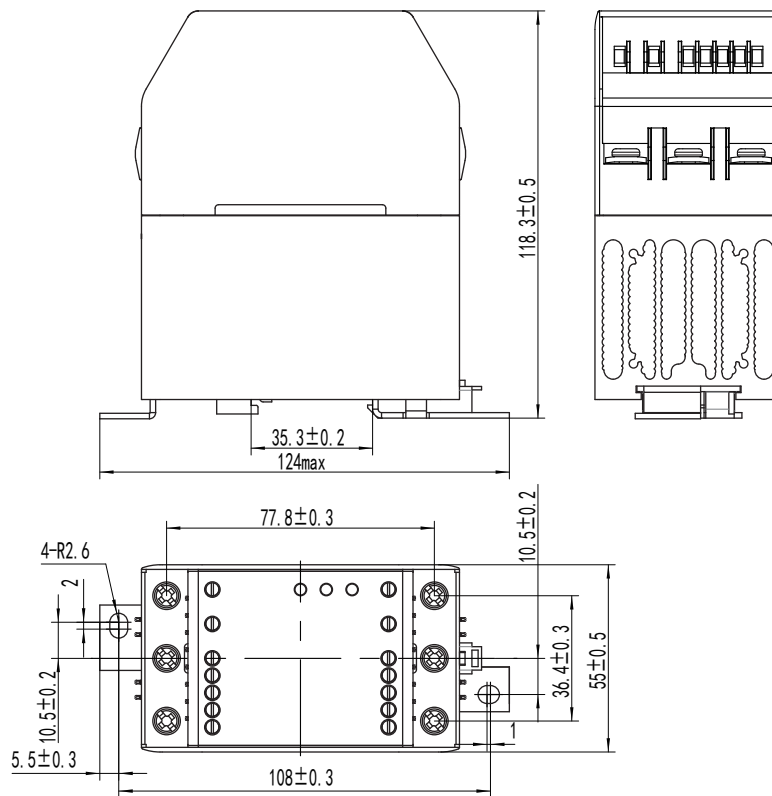

KRE...25... Series

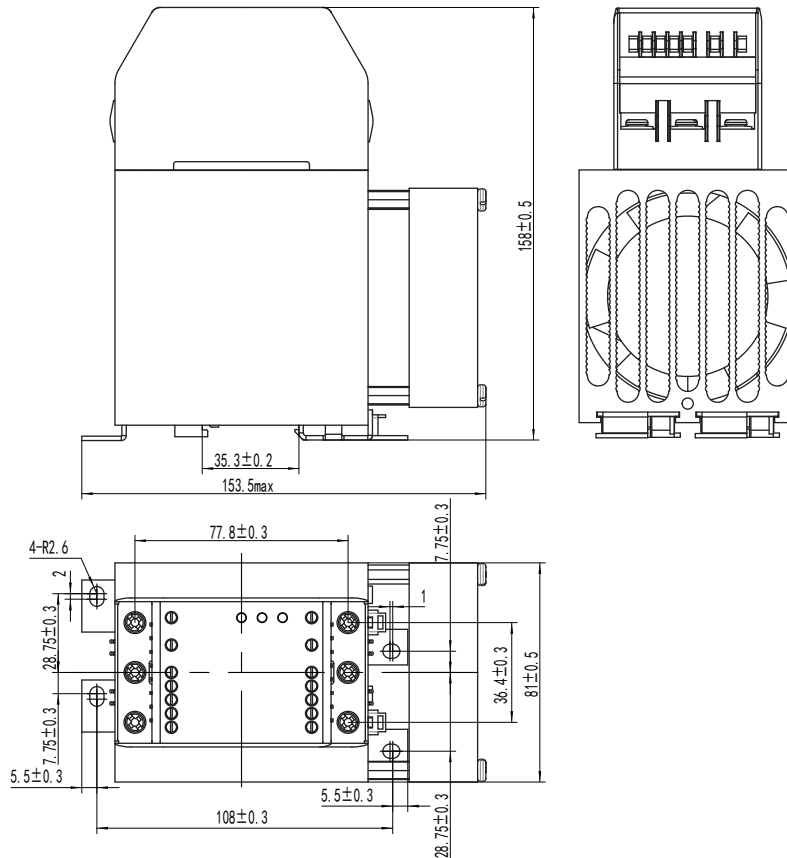

KRE...(40、60、80)...F... Series

接线图

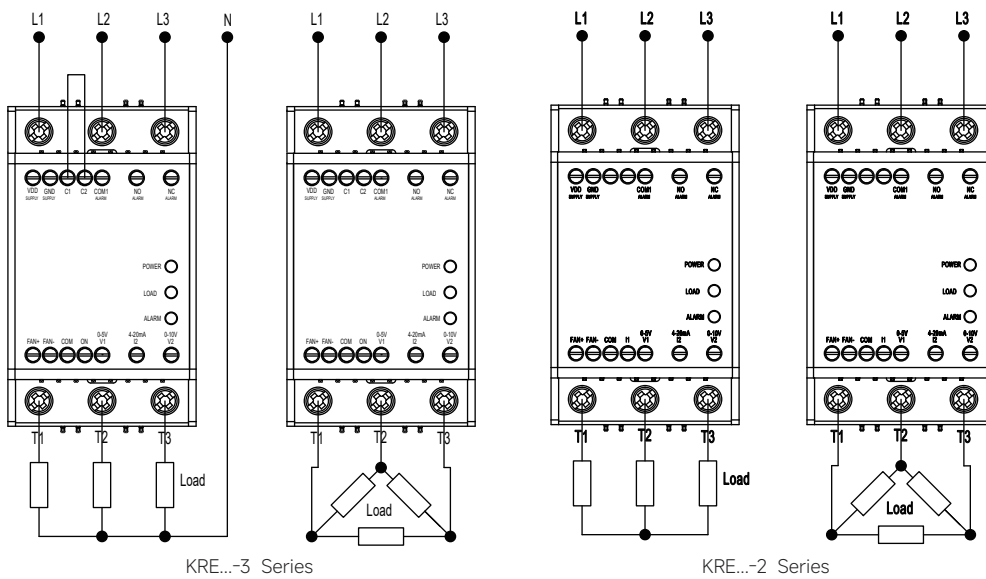

KRE...-3 Series

KRE...-2 Series

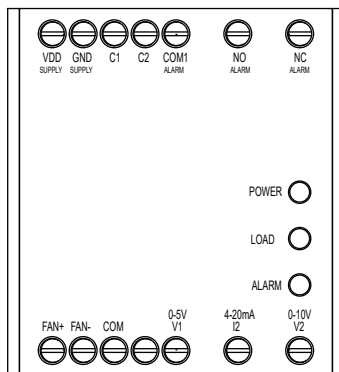

GND, COM: GND and COM are connected together as public negative end;
 VDD: The positive pole of auxiliary power supply;
 V1: The positive pole of 0-5VDC voltage control input;
 V2: The positive pole of 0-10VDC voltage control input;
 I2: The positive pole of 4-20mA current control input;
 ON: When an analog quantity is applied to the control terminal and it is at a high level, the SSR turns on; when it is at a low level, the SSR turns off (Only for the KRE... - DE... series).
 C1, C2: Load type selection --- if C1, C2 suspension then the load does not connect with zero line; if C1, C2 is short connection, then the load connects with zero line;
 Power LED (POWER, RED): LED is lighted when with APS;
 Connection LED (LOAD, GREEN): LED is lighted when the load has an output;
 Fault LED (ALARM, RED): LED is lighted when SSR has a failure;
 FAN+: 24VDC DC FAN positive pole;
 FAN-: 24VDC DC FAN negative pole;
 NC: EMR output normally closed alarm contacts;
 NO: EMR output normally open alarm contacts.
 COM1: EMR output common end.

Output / Proportional Control Features

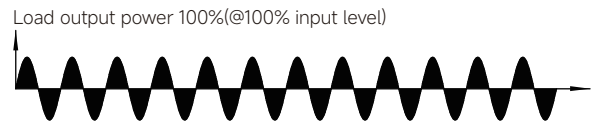
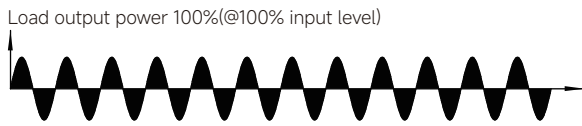
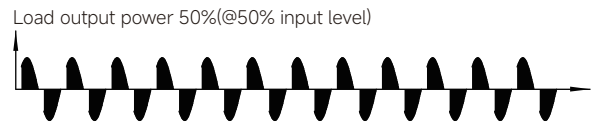
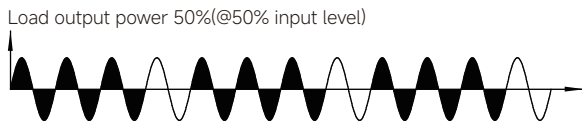
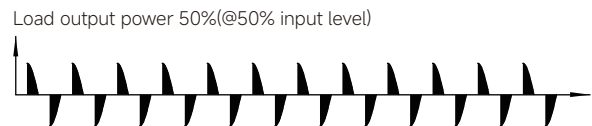
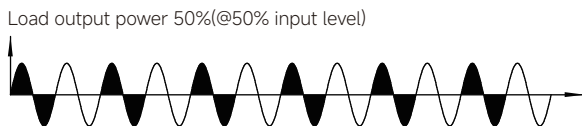
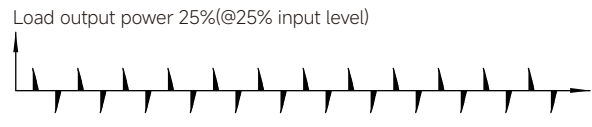
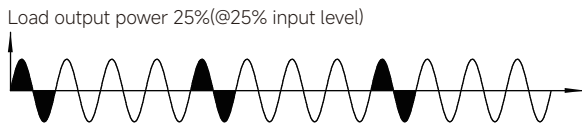
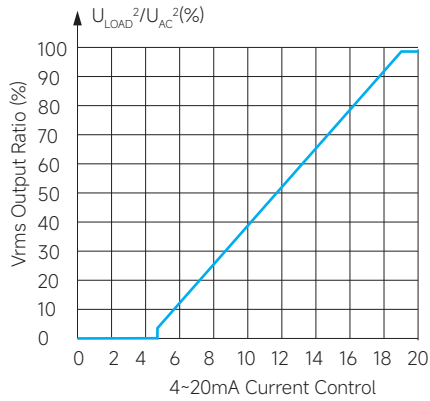
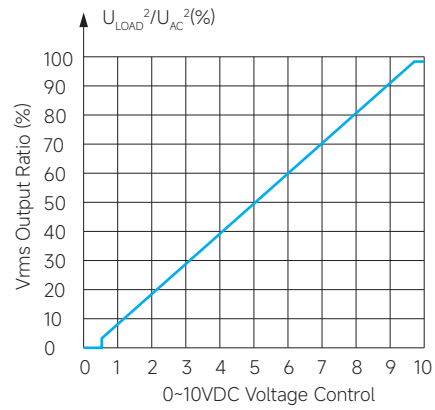
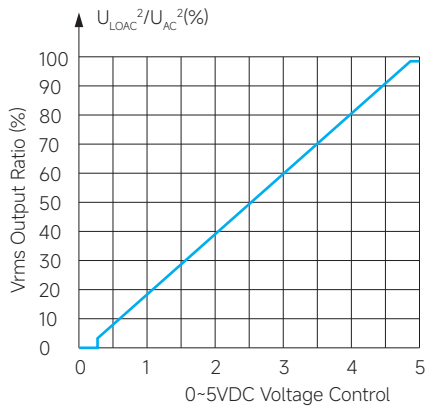

Full Cycle Switching

Phase Angle Switching

Thermal Derating Curve

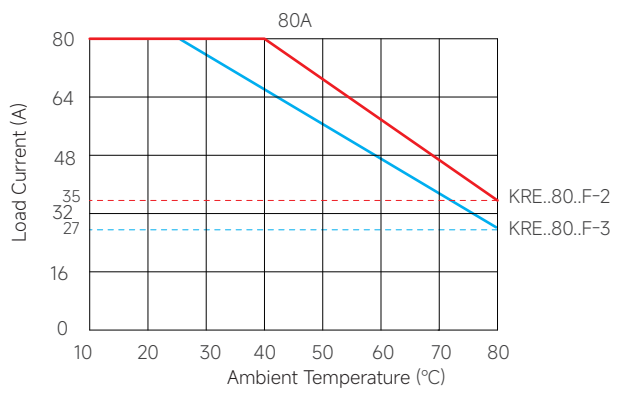
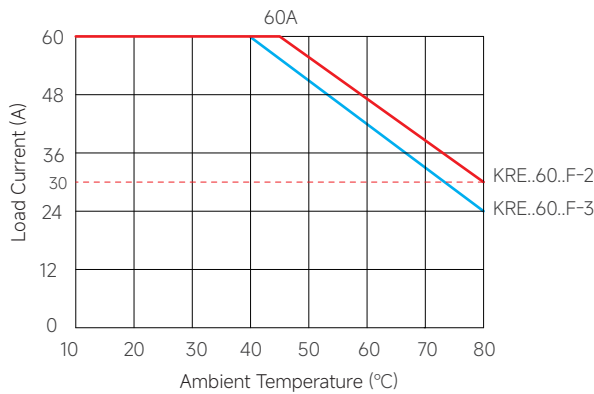
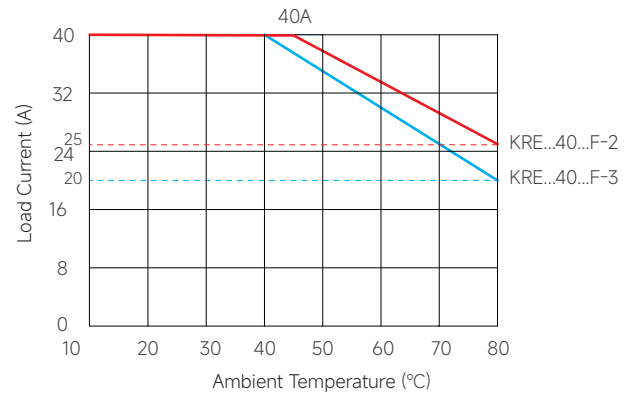
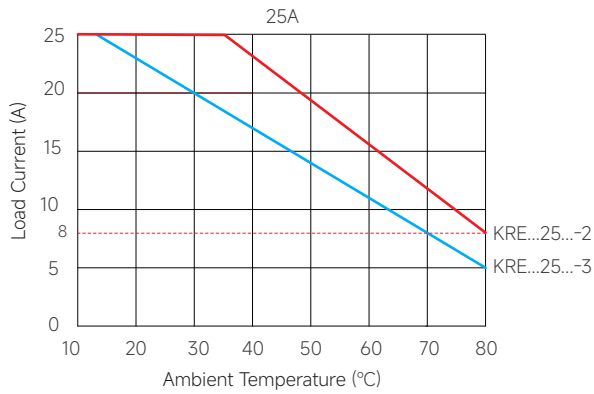

General Notes

1. When the operation temperature is high, please consider the derating as per the thermal curve.
2. The product's terminal should ensure reliable connection; poor connection may lead to the product overheating and damaging the product;
3. Input torque is recommended as (0.35-0.45) N·m while output M4 terminal torque is recommended as (0.98-1.37) N·m.
4. This product has a built-in fault detection circuit, so the L1, L2, L3 of the product must be connected with the phase line. T1, T2, T3 can work normally, and the phase line is inverted with the load.
5. Ensure the electrical grounding reliably during the use of the SSR.
6. Since this product regulates the voltage across the load through chopper modulation, the voltage waveform at the load terminals is not a standard sine wave. Therefore, when measuring the voltage across the load, a meter labeled "TRUE RMS" should be used. Common multimeters typically employ average-responding measurement, which is only suitable for sine wave measurements. When measuring non-sinusoidal voltage waveforms, the readings from such multimeters are often lower than those obtained with a TRUE RMS meter. The greater the waveform distortion, the larger the discrepancy between the two values.
7. Metal filament infrared lamps can generate extremely high surge currents at the moment of turn on, which may damage the product due to excessive surge current. Therefore, when controlling such loads, the analog signal must undergo soft-start during startup to suppress the surge current and prevent damage to the product.
8. This product is suitable for resistive loads. If you need to control inductive loads, please consult our technical personnel.



Warnings

1. The product may be hot, allow the product to cool before touching.
2. Disconnect all power before installing or working with this equipment.
3. Verify all connections and replace all covers before turning on power.
4. For non-sinusoidal waveforms, only True RMS meters can provide accurate voltage measurements. Standard multimeters may underreport the actual values under high distortion conditions.