

Product Description

- ◆ MOSFET Output
- ◆ Low Impedance
- ◆ Control Voltage: 4-15VDC or 15-32VDC
- ◆ Internal Over-voltage Protection
- ◆ Photoelectric Isolation
- ◆ Dielectric Strength: 2500Vrms
- ◆ Panel Mount
- ◆ LED Indicator
- ◆ RoHS Compliant



Product Selection

KSJB	30	LD	10	(XXX)
KSJB Series	Load Voltage 30: 0-24VDC 60: 0-48VDC 100: 0-75VDC 200: 0-120VDC	Control Mode LD: 4-15 VDC HD: 15-32 VDC	Load Current 10:10Amp 20:20Amp 40:40Amp 50:50Amp	Customized Code

Available Part Numbers

Control Mode	Load Voltage	10A	20A	40A	50A
LD:4-15VDC	30VDC				KSJB30LD50
	60VDC				KSJB60LD50
	100VDC		KSJB100LD20	KSJB100LD40	
	200VDC	KSJB200LD10			
HD:15-32VDC	30VDC				KSJB30HD50
	60VDC				KSJB60HD50
	100VDC		KSJB100HD20	KSJB100HD40	
	200VDC	KSJB200HD10			

Technical Specifications

Input Specifications (Ta=25°C)		
Control Voltage Range	LD	4-15VDC
	HD	15-32VDC
Must Turn-on Voltage	LD	4VDC
	HD	15VDC
Must Turn-off Voltage		2VDC
Maximum Input Current	LD	25mA@15VDC
	HD	25mA@32VDC
Maximum Reverse Voltage	LD	15VDC
	HD	32VDC

Output Specifications (Ta=25°C)					
Ordering Informationc	KSJB30...50	KSJB60...50	KSJ100...20	KSJB100...40	KSJB200...10
Transistor Voltage (VDC)	55	100	150	150	250
Load Voltage Range (VDC)	0-24	0-48	0-75	0-75	0-120
TVS Breakdown Voltage Scope (V)	371-41	64.6-71.4	105-116	105-116	190-210
Maximum Load Current (A)	50	50	20	40	10
Maximum SurgeCurrent (A _{pk} @10ms)	150	150	60	120	30
Maximum On-State Resistance (mΩ)	4.2	12	6.2	6.2	60
Maximum Off-State Leakage Current@Rated Load Voltage (mA)			0.1		
Minimum Load Current (mA)			2		
Maximum Turn-on Time (ms)			0.3		
Maximum Turn-off Time (ms)			0.3		

General Specifications (Ta=25°C)		
Dielectric Strength (50/60Hz)	Input/Output	2500Vrms
	Input, output/Base	2500Vrms
Insulation Resistance (@500VDC)	1000MΩ	
Operating Temperature Range	-30°C~+80°C	
Storage Temperature Range	-30°C~+100°C	
Weight (Typ)	150g	

Applications

DC heating, DC power supply, DC valve, DC motor, medical equipment, etc.

Outline Dimensions

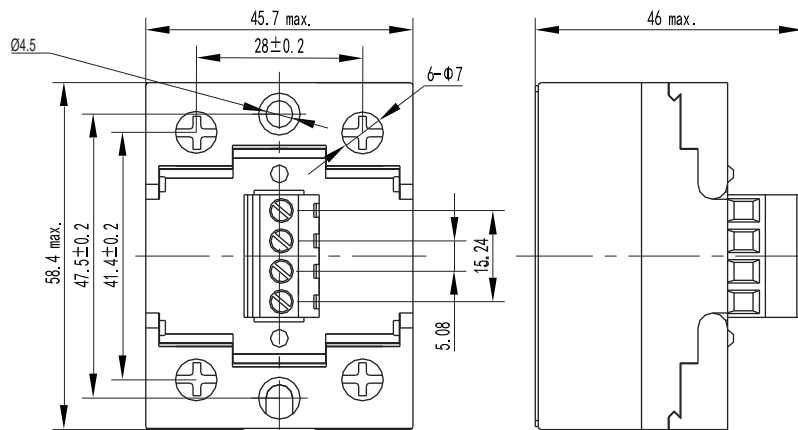

Wiring Diagram

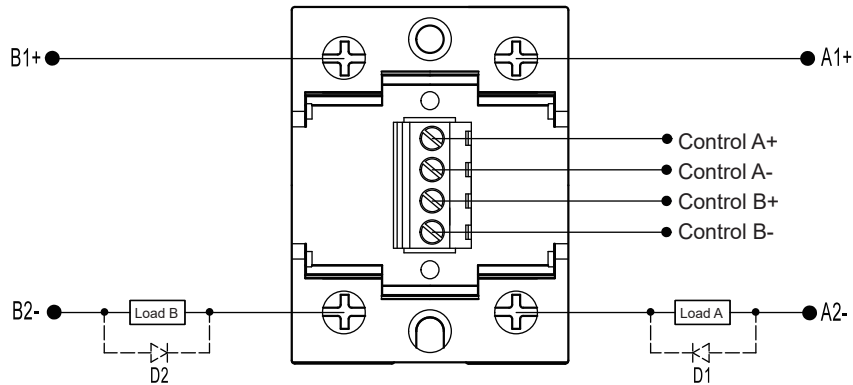

When the relay is used for inductive load control, please be sure to use a suppression circuit, just like the drawing above. Both load terminals are inverse parallelled with fly-wheel diodes D1, D2 .
D1, D2: Fast Recovery Diode

Thermal Derating Curve

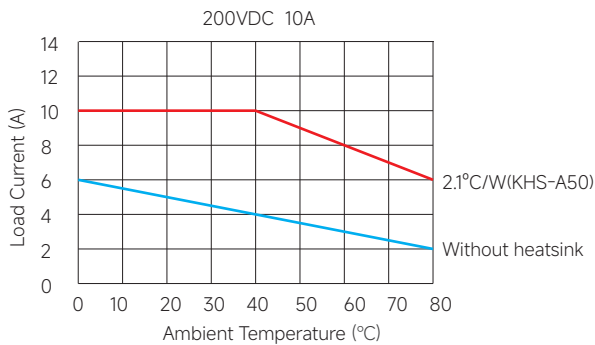
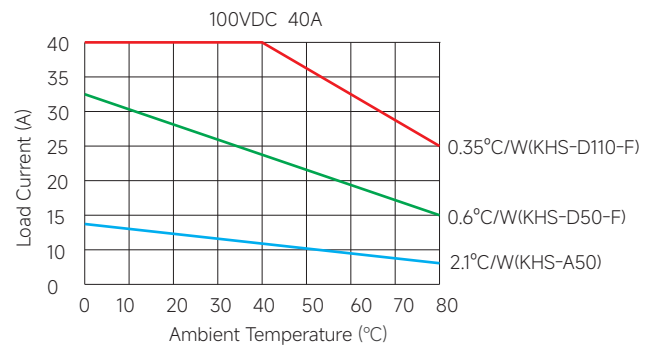
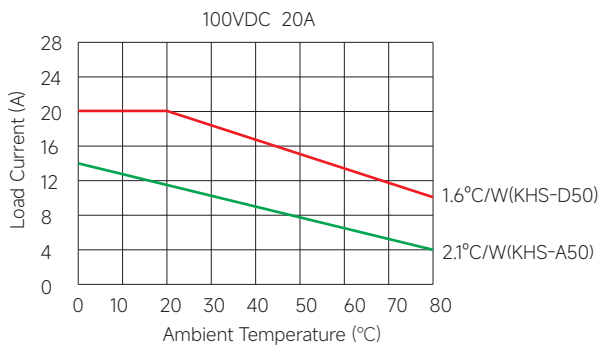
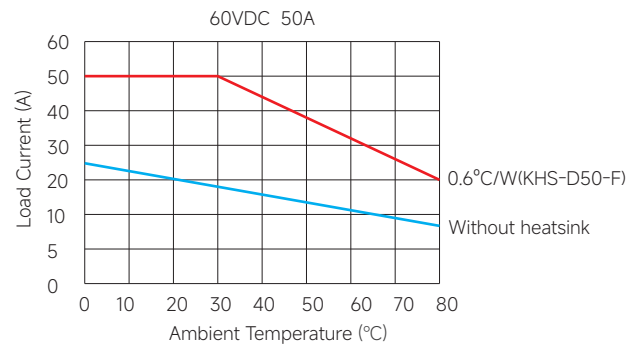
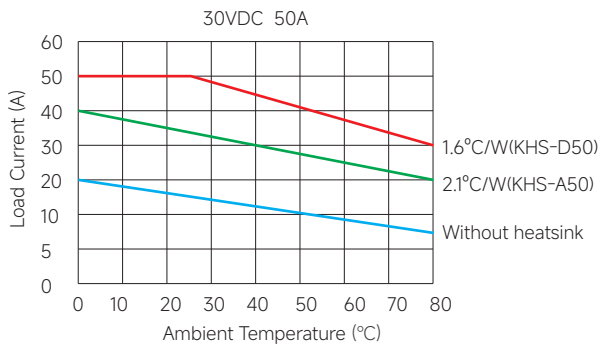

Note: The curve above shows the heatsink capability under the worst case (100% continuous operation) for a solid state relay. If your application involves intermittent operation, please contact us with your actual operating conditions (load current, on/off time, ambient temperature, etc.), and we will recommend the most suitable solution for you.

The above temperature curve is configured with radiator models as follows:

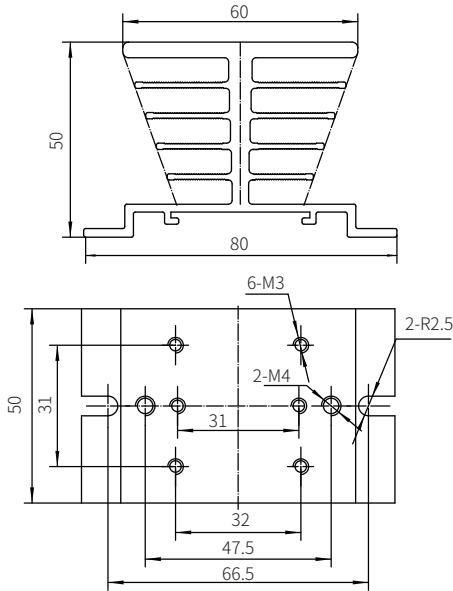

KHS-A50

(Note: The recommended mounting hole size is 68mm)

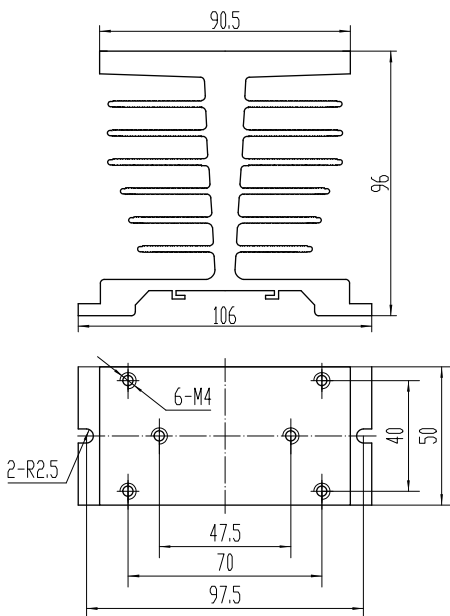

KHS-D50

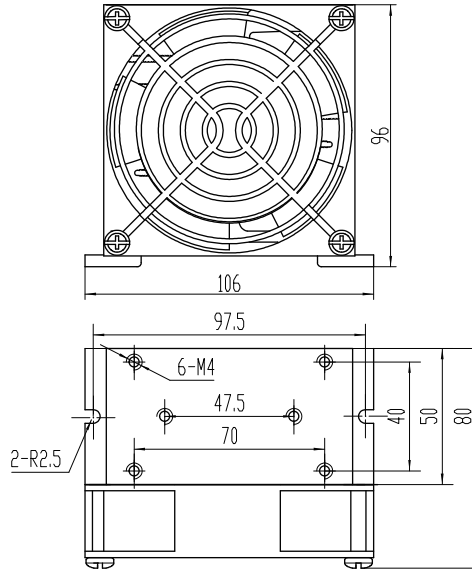

KHS-D50-F

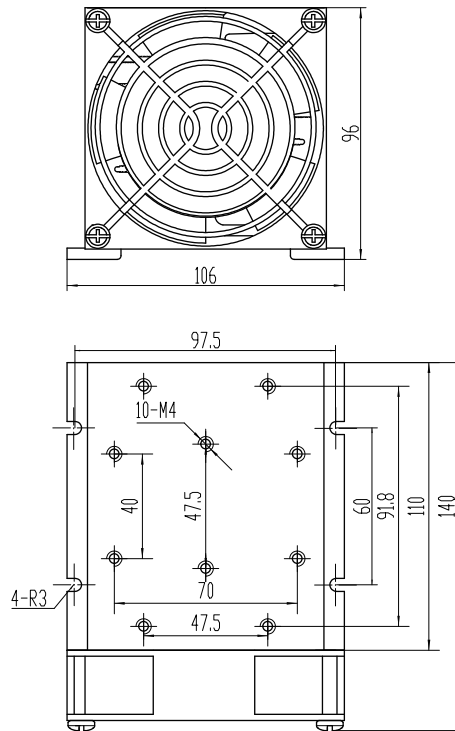

KHS-D110-F

General Notes

1. The heat generated by the relay needs to be dissipated through the bottom plate, and it is necessary to ensure that the relay base plate is in close contact with the heat sink and installed firmly, and the contact surface needs to be covered with thermal pad or thermal grease.
2. The relay terminal should ensure that the wiring is firm because the loose wiring will cause the product to heat up abnormally and damage the product. The recommended installation torque for M3 terminals is $(0.2\sim 0.5)\text{N}\cdot\text{m}$, and for M4 terminals the recommended installation torque is $(0.98\sim 1.37)\text{N}\cdot\text{m}$.
3. When the ambient temperature is high, please refer to the temperature curve to derate.
4. For the capacitive load, at the moment of turning on, an extremely high inrush current will happen, which may cause SSR to be damaged due to excessive inrush current. Therefore, if the load is a capacitive load, or if the load is equipped with a large capacitor in parallel, it is strongly recommended to connect the NTC in series in the load circuit to suppress the inrush current to avoid damage to the product.

! Warnings

1. The product may be hot, allow the product to cool before touching.
2. Disconnect all power before installing or working with this equipment.
3. Verify all connections and replace all covers before turning on power.