

**Product Description**

- ◆ Zero Crossing or Random-on Switching
- ◆ Ratings from 15A~125A @24~660VAC
- ◆ SCR Output or TRIAC Output
- ◆ DC or AC Input
- ◆ Dielectric Strength: 4000VACrms
- ◆ LED Indication
- ◆ TVS Protection (Optional)
- ◆ IP20 touch-safe housing



**Product Selection**

<b>KSN</b>	<b>480</b>	<b>D</b>	<b>80</b>	<b>T</b>	<b>R</b>	<b>N</b>	<b>-L</b>	<b>T</b>	<b>(XXX)</b>
KSN Series	Load Voltage 240: 240VAC 480: 480VAC 600: 600VAC	Control Mode D: DC Control A: AC Control	Load Current <sup>(1)</sup> 15: 15Amp 25: 25Amp 40: 40Amp 50: 50Amp 60: 60Amp 75: 75Amp 80: 80Amp 100: 100Amp 125: 125Amp	Output Mode T: TRIAC Output <sup>(2)</sup> None: SCR Output	Switching Mode Blank: Zero Crossing R: Random-on	Blank: With RC N: Without RC	L: LED	Protection Type T: TVS Protection Blank: Without Protection	Customized Code

Note: (1) 15A version is only available for 240V or 480V load voltage version.

(2) 15A version is Triac output, 25A/40A version are available with SCR or Triac output, 50A/60A/75A/80A/100A/125A are all SCR output.

**Technical Specifications**

Input Specifications (Ta=25°C)	Condition	Symbol	Model	Min	Typ	Max	Unit	
Control Voltage		U <sub>c</sub>	DC Control	3	24	32	VDC	
			AC Control	90	220	280	VAC	
Input Current (Typ)	@U <sub>c</sub>	I <sub>c</sub>	DC Control	KSN240... Series	9	13	13	mA
			DC Control	KSN480/600... Series	15	20	21	mA
			AC Control		9.5	22	28	mA
Must Turn-on Voltage		U <sub>c on</sub>	DC Control		3		VDC	
			AC Control		90		VAC	
Must Turn-off Voltage		U <sub>c off</sub>	DC Control		1		VDC	
			AC Control		15		VAC	

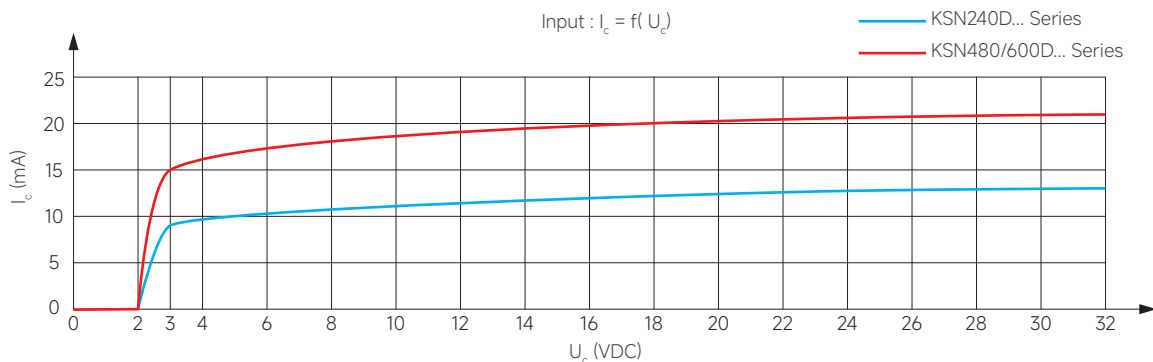

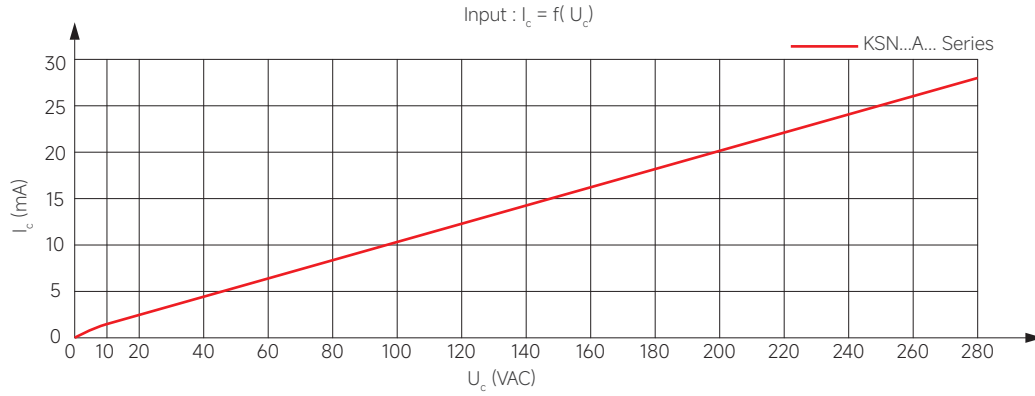

Output Specifications (Ta=25°C)	Condition	Symbol	Model	Min	Typ	Max	Unit
Load Voltage		$U_e$	240V	24		280	VAC
			480V	24		530	VAC
			600V	24		660	VAC
Load Current		$I_e$		100		mA	
Turn-On Time		$t_{on}$	DC Control Zero-crossing			1/2cycle+1ms	ms
			DC Control Random-on			1	ms
			AC Control			40	ms
Turn-Off Time		$t_{off}$	DC Control			1/2cycle+1ms	ms
			AC Control		20		ms
On-State Voltage Drop	@ Rated Load Current	$U_d$			1.1	1.5	Vrms
Off-State Leakage Current	@ Rated Load Voltage	$I_{lk}$	With RC		3		mA
			Without RC		0.1		mA
On-State Resistance		f		47		63	Hz
Non-repetitive Surge Current	@10ms	$I_{TSM}$	15A		150		A
			25A	SCR Output	300		A
				TRIAC Output	250		A
			40A	SCR Output	500		A
				TRIAC Output	400		A
			60A		600		A
			60A		700		A
			80A		800		A
			100A		1100		A
125A		2250		A			
Maximum $I^2t$ for Fusing	@10ms	$I^2t$	15A		112		A <sup>2</sup> s
			25A	SCR Output	450		A <sup>2</sup> s
				TRIAC Output	312		A <sup>2</sup> s
			40A	SCR Output	1250		A <sup>2</sup> s
				TRIAC Output	880		A <sup>2</sup> s
			50A		1800		A <sup>2</sup> s
			60A		2450		A <sup>2</sup> s
			75A		2812		A <sup>2</sup> s
			80A		3200		A <sup>2</sup> s
100A		6050		A <sup>2</sup> s			
125A		25000		A <sup>2</sup> s			
Transient Overvoltage		$U_p$	240V		600		Vpk
			480V		1200		Vpk
			600V		1200		Vpk
Minimum Off-State		dv/dt	SCR Output		500		V/μs
			TRIAC Output		200		V/μs
Minimum Power Factor		cosφ			0.5		

General Specifications (Ta=25°C)	Condition	Symbol	Model	Min	Typ	Max	Unit
Dielectric Strength	50/60Hz, Input/Output	$V_{ISO}$	SCR Output TRIAC Output		4000		Vrms
	50/60Hz, Input,Output/Base			SCR Output	4000	Vrms	
				TRIAC Output	2500	Vrms	
Insulation Resistance	@500VDC	$R_{ISO}$		100		MΩ	
Operating Temperature		$T_{OPR}$		-30		+80	°C
Storage Temperature		$T_{SPR}$		-30		+100	°C
Weight			SCR Output		80		g
			TRIAC Output		75		g

### Applications

High-low Temperature Chamber, Food processing machinery, Plastics processing Machinery.

### Outline Dimensions

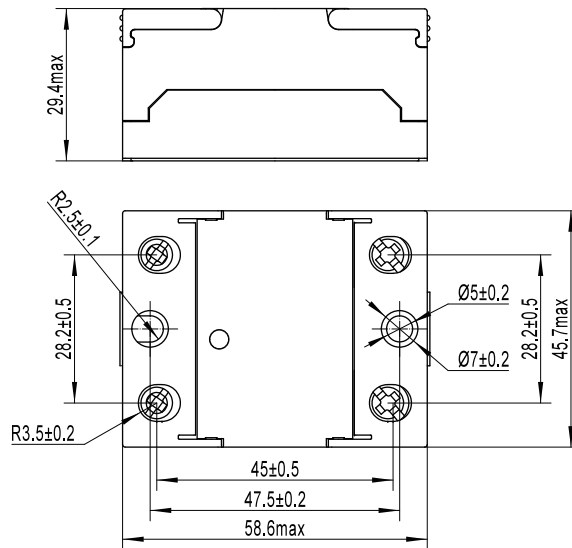

### Wiring Diagram

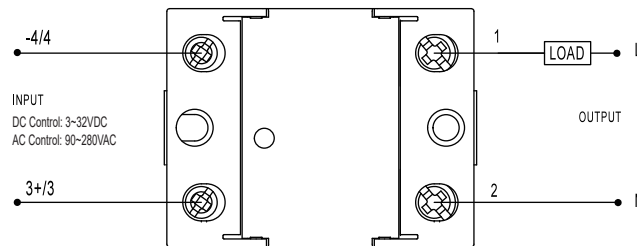

Wiring instruction:

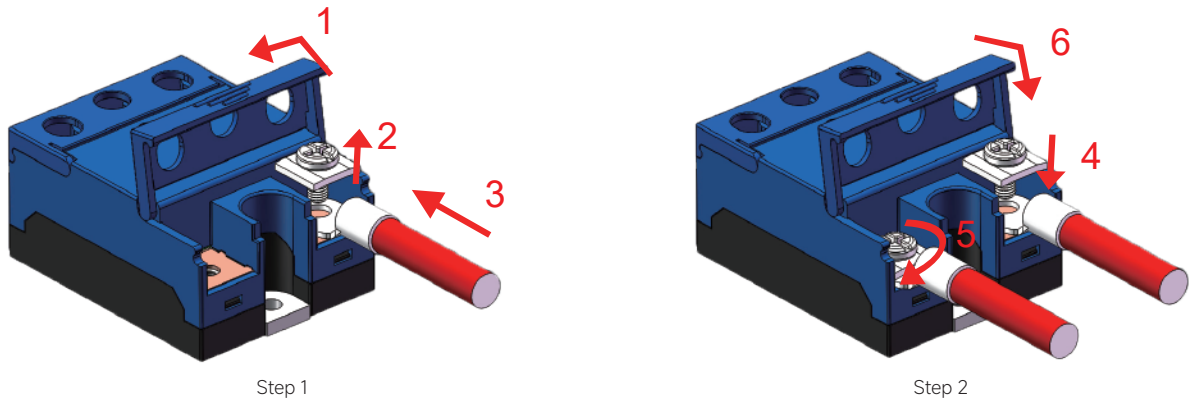

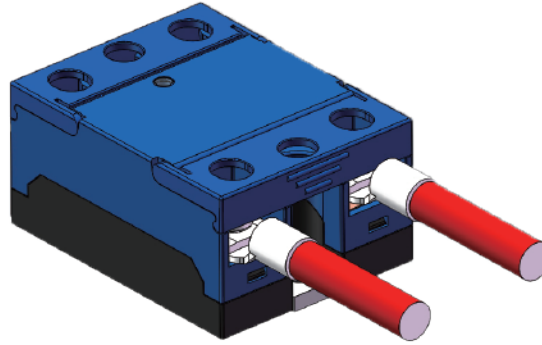

Step 3

RECOMMENDATION FOR WIRING:

Load current (A)	Wire size (AWG)	Cross section area of wire (mm <sup>2</sup> ) <sup>(3)</sup>	DIN 46234 terminal model	Terminal mounting hole size D (mm)	Terminal width W(mm)
15-20	12	2.5	4-6	4.3	8
			5-6	5.3	10
20-35	10	4	4-6	4.3	8
			5-6	5.3	10
25-32	10	6	4-6	4.3	8
			5-6	5.3	10
32-50	8	10	5-10	5.3	10
50-65	6	16	5-16	5.3	11
65-85	4	25	5-25	5.3	12

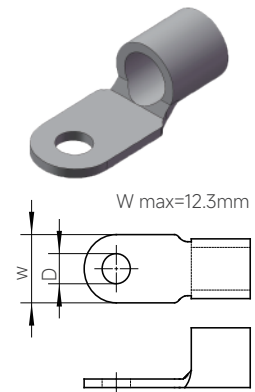

Note: (3) When use the wire cross-sectional area greater than 25mm<sup>2</sup>, we suggest to break it in to two smaller wires and connect them back to back superimposed.

Thermal Derating Curve

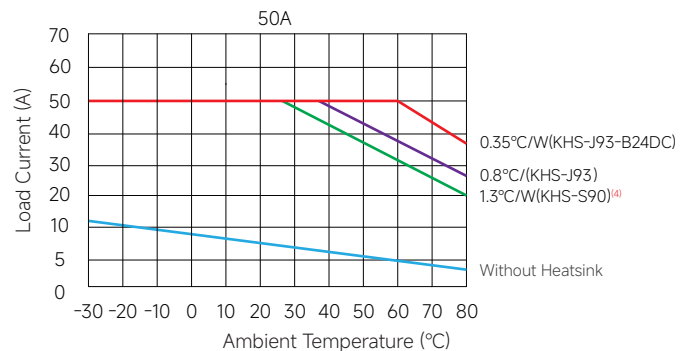
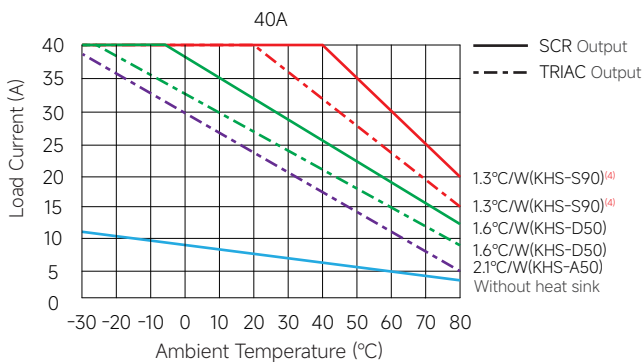
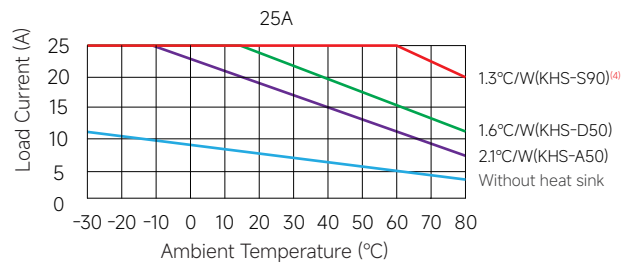
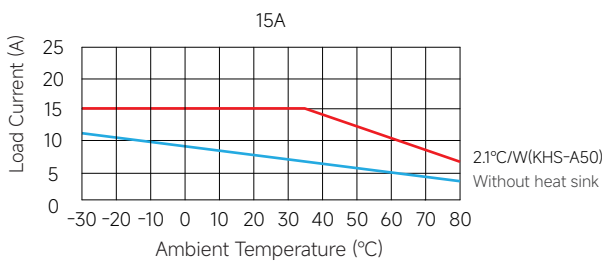

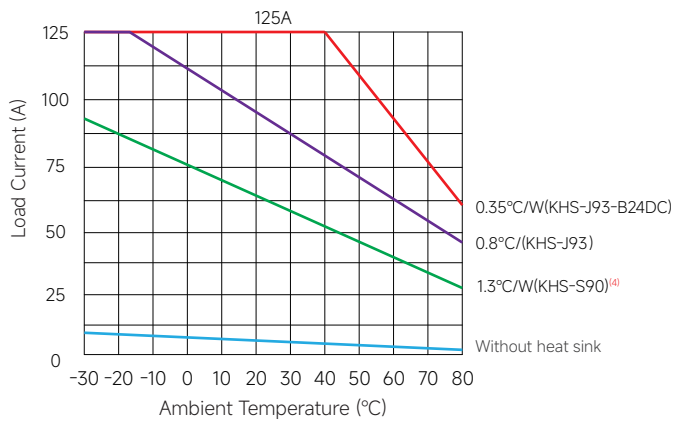
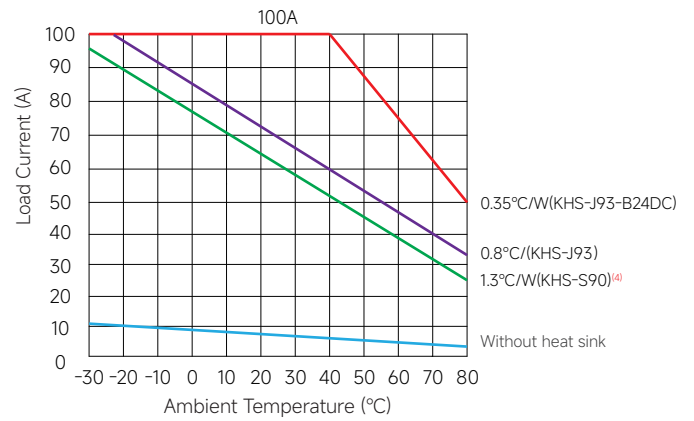
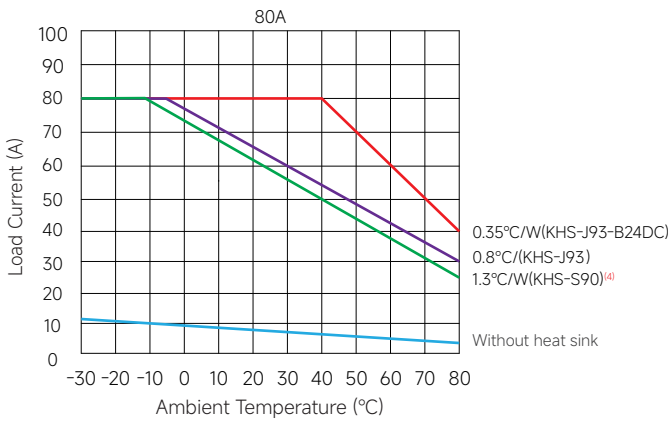
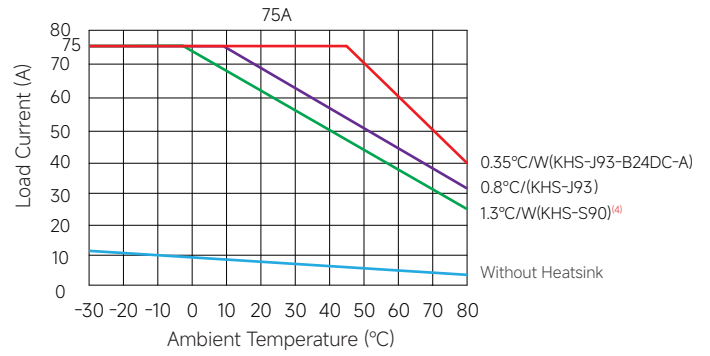
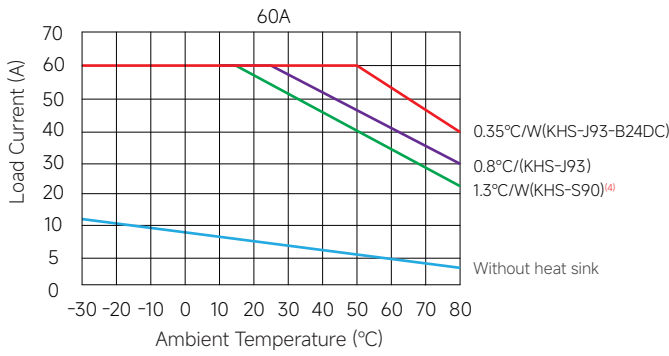

Note: (4) The standard installation direction for the 1.3 °C/W (KHS-S90) radiator is to install the exhaust hole vertically up and down. Installing in other directions will reduce the heat dissipation effect of the radiator. The curve above shows the heatsink capability under the worst case (100% continuous operation) for a solid state relay. If your application involves intermittent operation, please contact us with your actual operating conditions (load current, on/off time, ambient temperature, etc.), and we will recommend the most suitable solution for you.

The above temperature curve is configured with radiator models as follows:

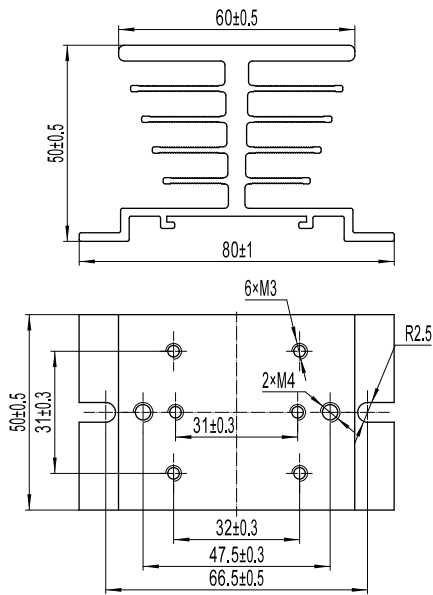

KHS-A50

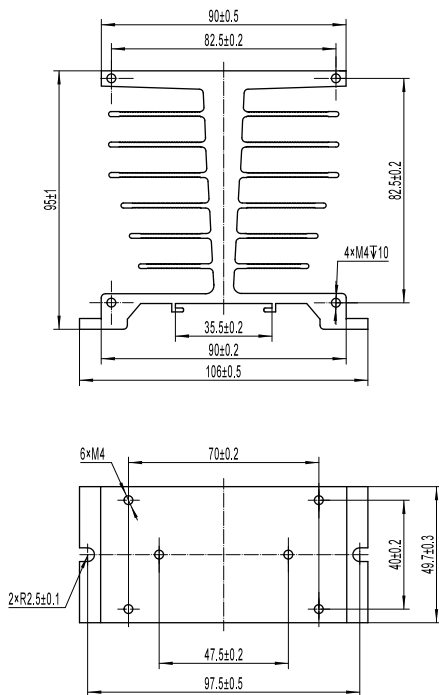

KHS-D50

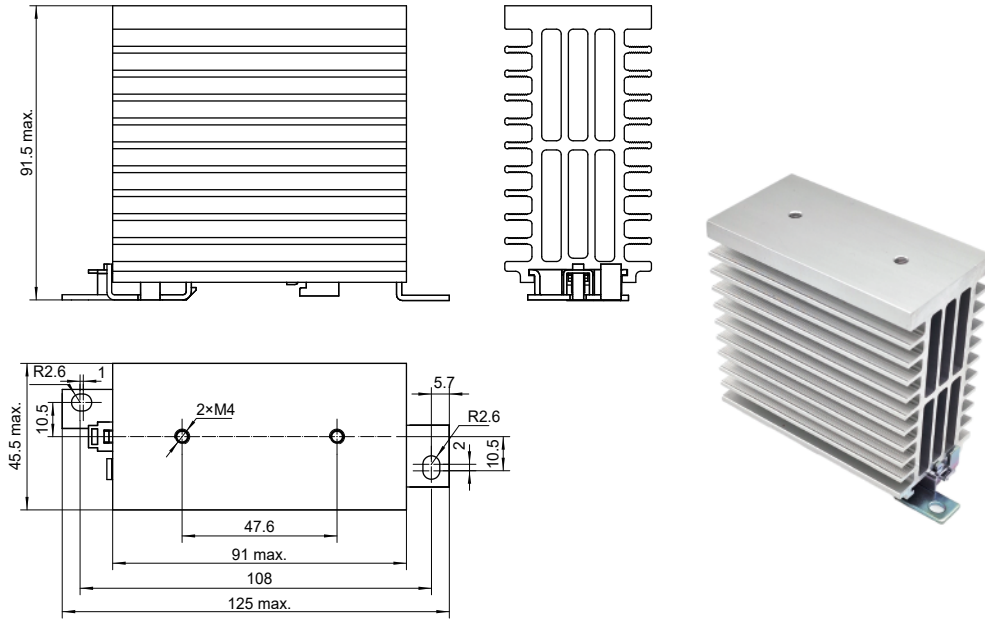

KHS-S90

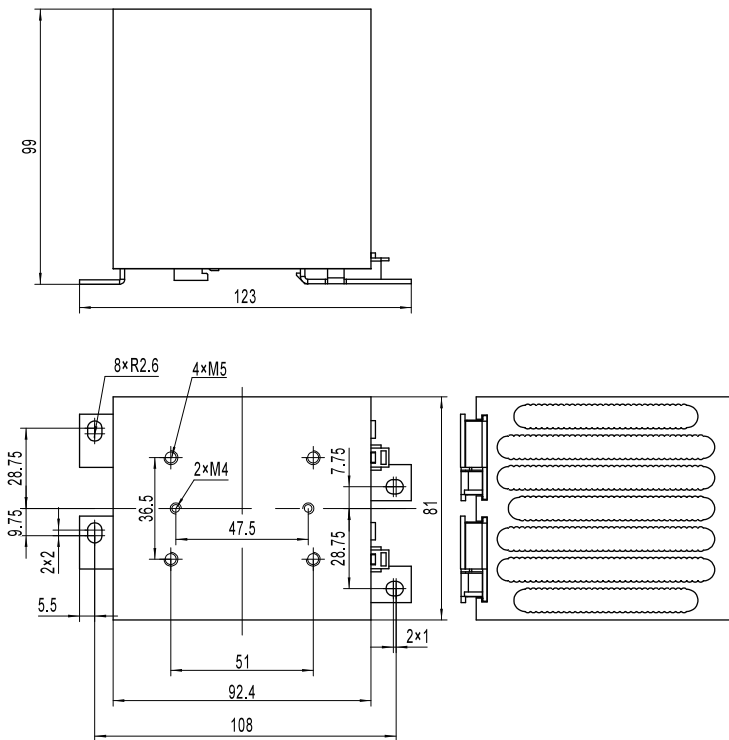

KHS-J93

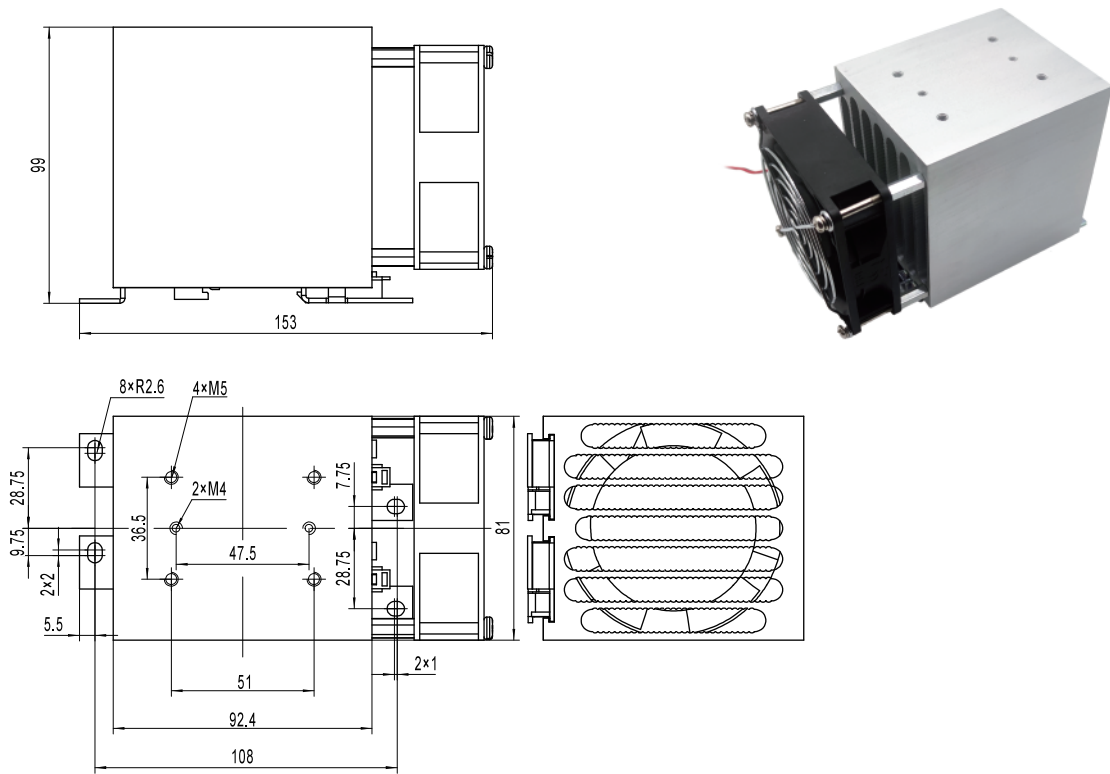

KHS-J93-B24DC

### General Notes

1. Relay must be mounted to proper sized heat sink based on thermal curves. Thermal grease or a thermal pad must be used between relay and heat sink and be torqued down to 8.7-12.1 in-lb / 0.98-1.37 Nm.
2. When connection wiring to SSR, please ensure screws are torqued down properly (input 5.1-8.7 in-lb / 0.58-0.98 Nm, output 8.7-12.1 in-lb / 0.98-1.37 Nm).
3. SSR's carrying load capacity is related to the operation ambient temperature and heat dissipation condition, please refer to the Thermal Derating Curve for derating.

### ! Warnings

1. The product's side panels may be hot, allow the product to cool before touching.
2. Disconnect all power before installing or working with this equipment.
3. Verify all connections and replace all covers before turning on power.