

Product Description

- ◆ Zero Crossing or Random-on Switching
- ◆ Load Current: 20A, 30A@24-660VAC
- ◆ SCR Output
- ◆ DC Input
- ◆ With Integrated Heatsink
- ◆ Dielectric Strength: 4000VACrms
- ◆ LED Indication
- ◆ Built-in RC Snubber Circuit
- ◆ Panel Mount or 35mm Rail DIN(EN50022)

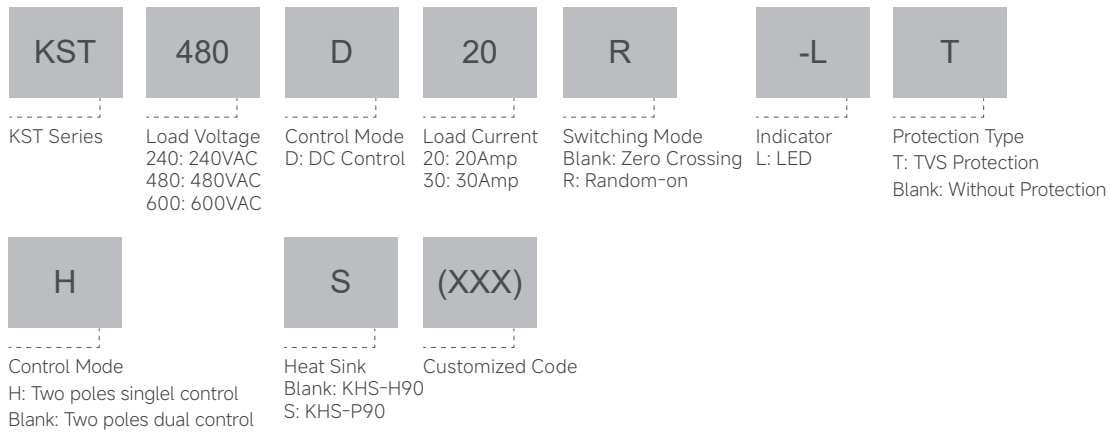

Product Selection



Technical Specifications

Input Specifications (Ta=25°C)		
Control Voltage Range		4-32VDC
Must Turn-on Voltage		4VDC
Must Turn-off Voltage		1VDC
Maximum Input Current	Two poles dual control	18mA (@32VDC)
	Two poles single control	35mA (@32VDC)
Output Specifications (Ta=25°C)		
Load Voltage Range	240V	24-280VAC
	480V	24-530VAC
	600V	24-660VAC
Maximum Turn-on Time	Random-on	1ms
	Zero Crossing	10ms
Maximum Turn-off Time		10ms
Maximum Surge Current (@10ms)	20A	250A
	30A	400A
Maximum I ² t for Fusing (@10ms)	20A	312A ² s
	30A	800A ² s
Transient Overvoltage	240V	600Vpk
	480V/600V	1200Vpk
TVS Breakdown Voltage Range ⁽¹⁾	240V	480V
	480V	960V
	600V	1200V
Maximum Off-State Leakage Current (@Rated Voltage)		5mA
Maximum On-State Voltage Drop (@Rated Current)		1.6Vrms
Minimum Off-State (dv/dt)		500V/μs

General Specifications (Ta=25°C)		
Dielectric Strength (50/60Hz)	Input/Output	4000Vrms
	Input,Output/Base	2500Vrms
Minimum Insulation Resistance (@500VDC)		1000MΩ
Min.Power Factor		0.5
Ambient Temperature Range		-30°C~+80°C
Storage Temperature Range		-30°C~+100°C
Weight (Typical)		553g

Note: (1)For the products with built-in TVS, it is rated as the typical operating voltage VBR of built-in TVS.

Applications

Plastic machinery, electric injection molding machine, packaging machine.

Outline Dimensions

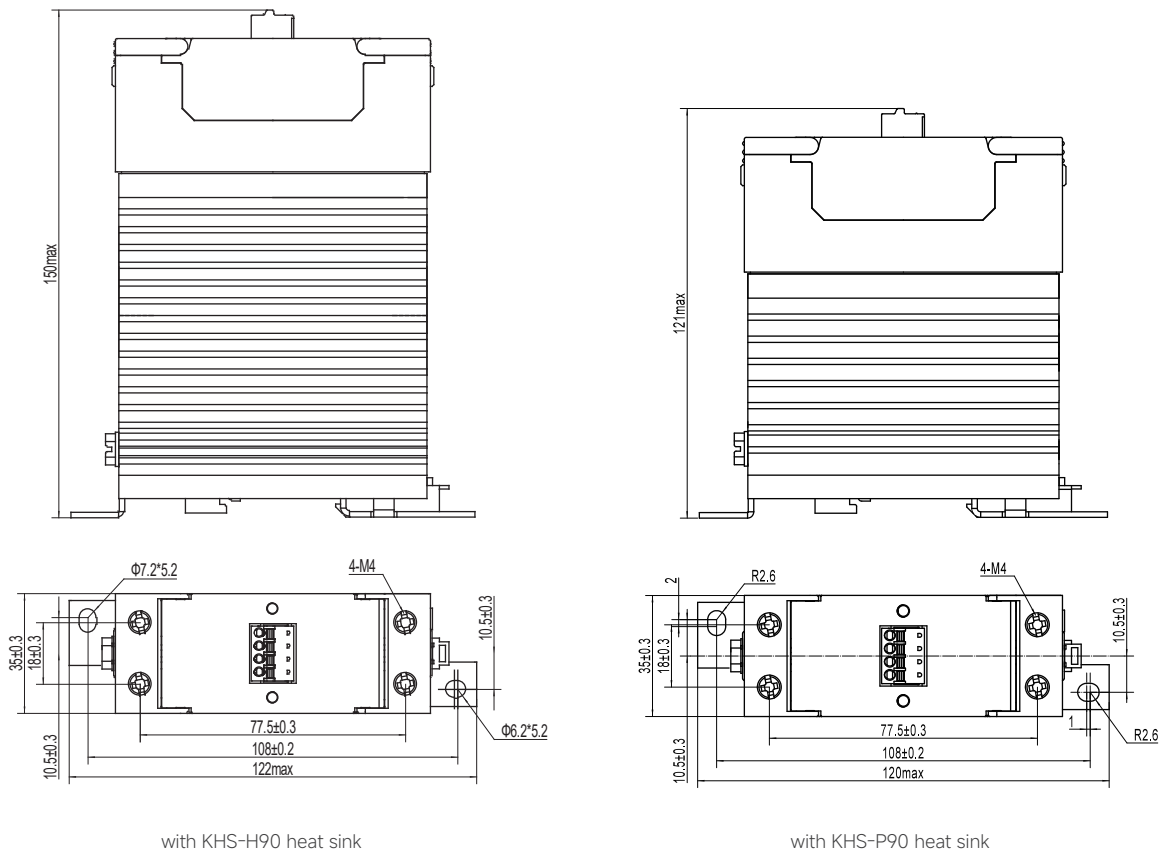

Wiring Diagram

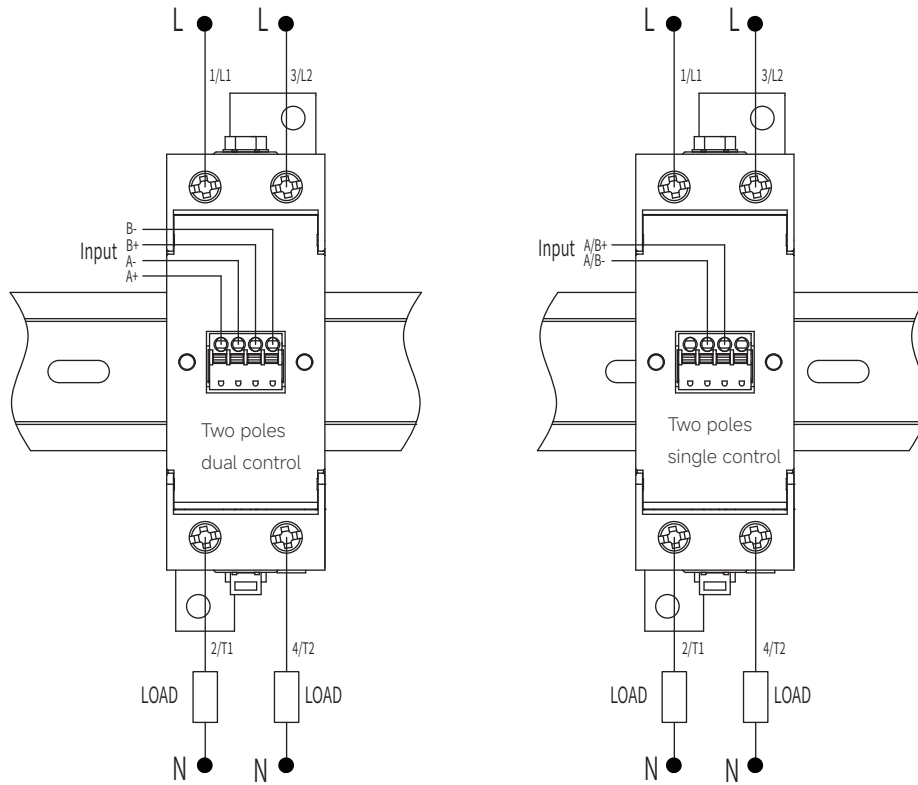

Thermal Derating Curve

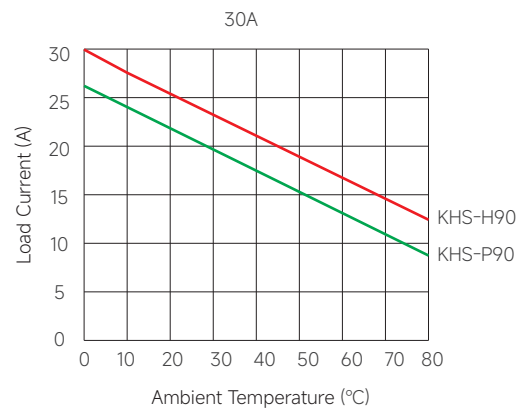
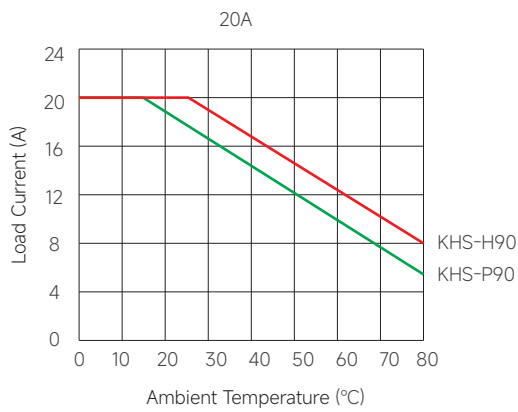

Note: The curve above shows the heatsink capability under the worst case (100% continuous operation) for a solid state relay. If your application involves intermittent operation, please contact us with your actual operating conditions (load current, on/off time, ambient temperature, etc.), and we will recommend the most suitable solution for you.

General Notes

1. SSR's carrying load capacity is related to the operation ambient temperature and heat dissipation condition, when there are many pieces SSR installed closely, please refer to the Thermal Derating Curve for derating.
2. When connection wiring to SSR, please ensure screws are torqued down properly. Recommended torque for input screw is (18-20)/(2.0-2.2) in-lb/Nm, output screw is (18-20)/(2.0-2.2) in-lb/Nm).

! Warnings

1. The product's side panels and heat sink may be hot, allow the product to cool before touching.
2. Disconnect all power before installing or working with this equipment.
3. Verify all connections and replace all covers before turning on power.