

Product Description

- ◆ Zero Crossing or Random-on Switching
- ◆ SCR Output
- ◆ DC or AC Input
- ◆ Load Current: 10A, 20A, 30A, 40A, 50A, 75A
- ◆ Dielectric Strength: 4000Vrms
- ◆ Built-in RC Snubber Circuit
- ◆ With Integrated Heatsink, Width 30mm(for 10~30A), 50mm (for 40A) or 105 mm (50A, 75A)
- ◆ 35mm Rail DIN(EN50022)
- ◆ LED Indicator
- ◆ RoHS Compliant



Product Selection

KSV	480	D	30	R	-L	T	(XXX)
KSV Series	Load Voltage 240: 240VAC 480: 480VAC 600: 600VAC	Control Mode D: DC Control A: AC Control	Load Current 10: 10Amp 20: 20Amp 30: 30Amp 40: 40Amp 50: 50Amp 75: 75Amp	Switching Mode Blank: Zero Crossing R: Random-on	L: LED	Protection Type T: TVS Protection Blank: Without Protection	Customized Code

Technical Specifications

Input Specifications (Ta=25°C)		
Control Voltage Range	DC Control	4-32VDC
	AC Control	90-280VAC
Must Turn-on Voltage	DC Control	4VDC
	AC Control	90VAC
Must Turn-off Voltage	DC Control	1VDC
	AC Control	15VAC
Maximum Input Current	25mA (@32VDC)	

Output Specifications (Ta=25°C)		
Load Voltage Range	240V	24-280VAC
	480V	24-530VAC
	600V	24-660VAC
Maximum Turn-on Time	DC Control Random-on	1ms
	DC Control Zero Crossing	10ms
	AC Control	40ms
Maximum Turn-off Time	DC Control	10ms
	AC Control	40ms
Maximum Surge Current (@10ms)	10A	200A
	20A	300A
	30A	500A
	40A	600A
	50A	650A
	75A	750A

Output Specifications (Ta=25°C)		
Maximum I ² t for Fusing (@10ms)	10A	200A ² s
	20A	450A ² s
	30A	1250A ² s
	40A	1800A ² s
	50A	2112A ² s
	75A	2812A ² s
Maximum Transient Overvoltage	240V	600Vpk
	480V	1200Vpk
	600V	1600Vpk
Maximum Off-State Leakage Current @Rated Load Voltage		10mA
Maximum On-State Voltage Drop @Rated Current		1.6Vrms
Minimum Off-State dv/dt @Maximum Rated Voltage		500V/μs
Minimum Power Factor		0.5

General Specifications (Ta=25°C)		
Dielectric Strength (50/60Hz)	Input/Output	4000Vrms
	Input, output/Base	2500Vrms
Insulation Resistance (@500VDC)		1000MΩ
Ambient Temperature Range		-30°C~+80°C
Storage Temperature Range		-30°C~+100°C
Weight (Typical)	10A/20A/30A	355g
	40A	540g
	50A	440g
	75A	1062g

Applications

Suitable for Temperature Chamber, Injection Molding Machine, Packaging Machine, and etc.

Outline Dimensions

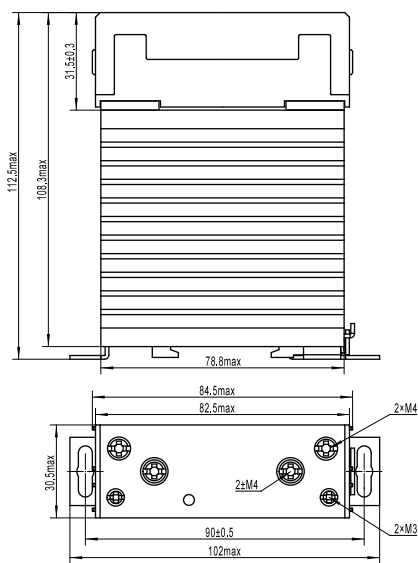

10-30A

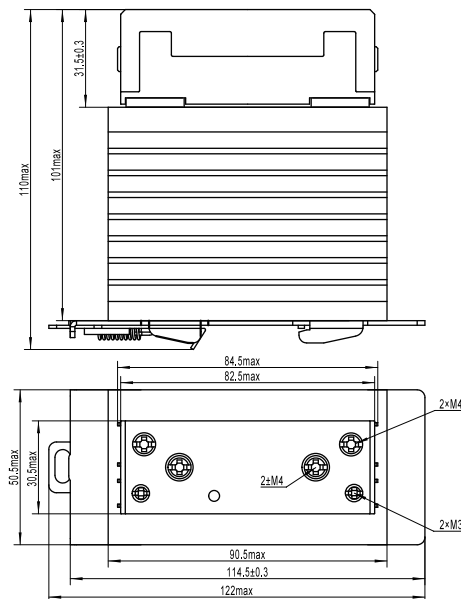

40A

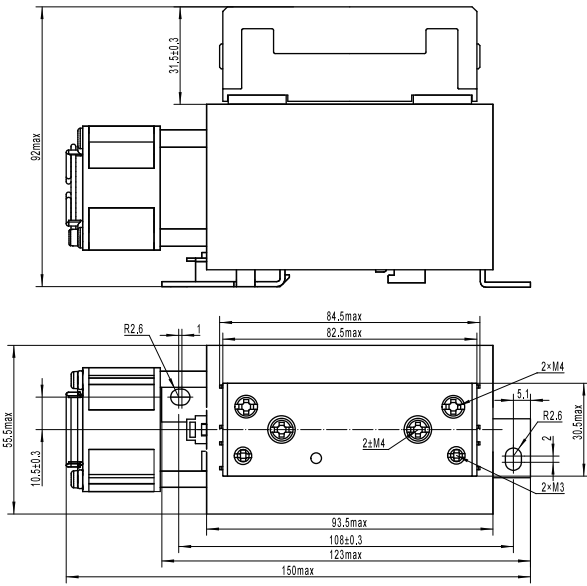

50A

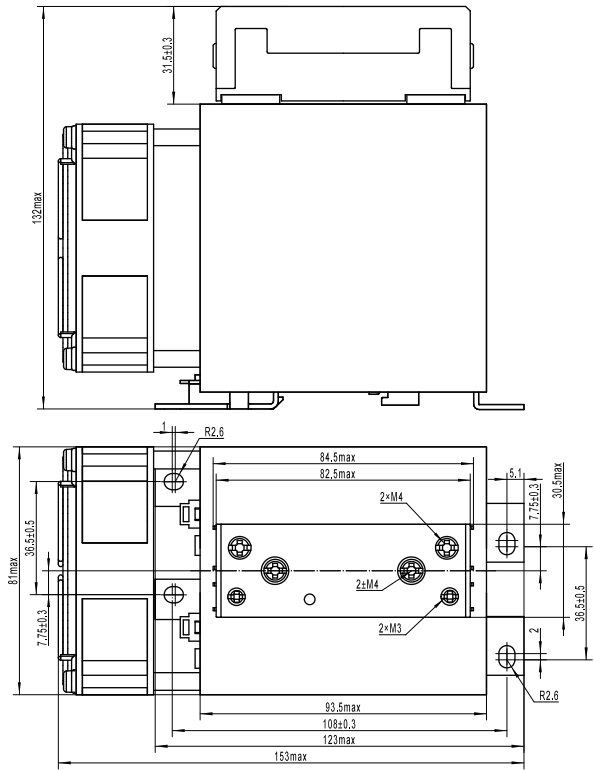

75A

Wiring Diagram

When mounting relays side by side please see recommended minimum spacing below.

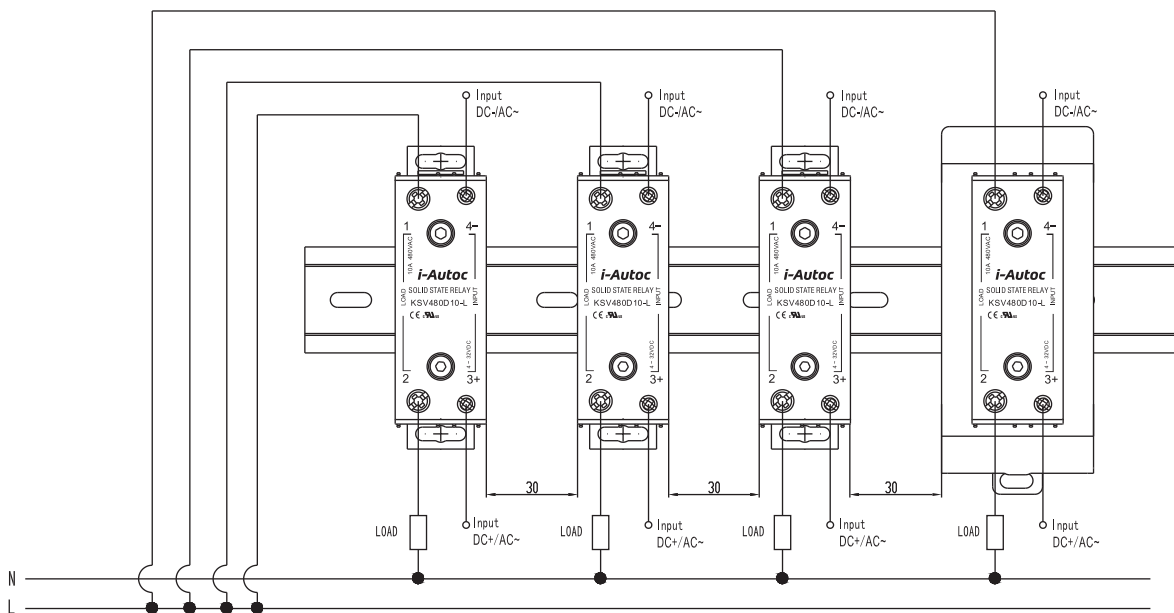

Installation Instructions

Mounting and dismounting on DIN rail without any tool.

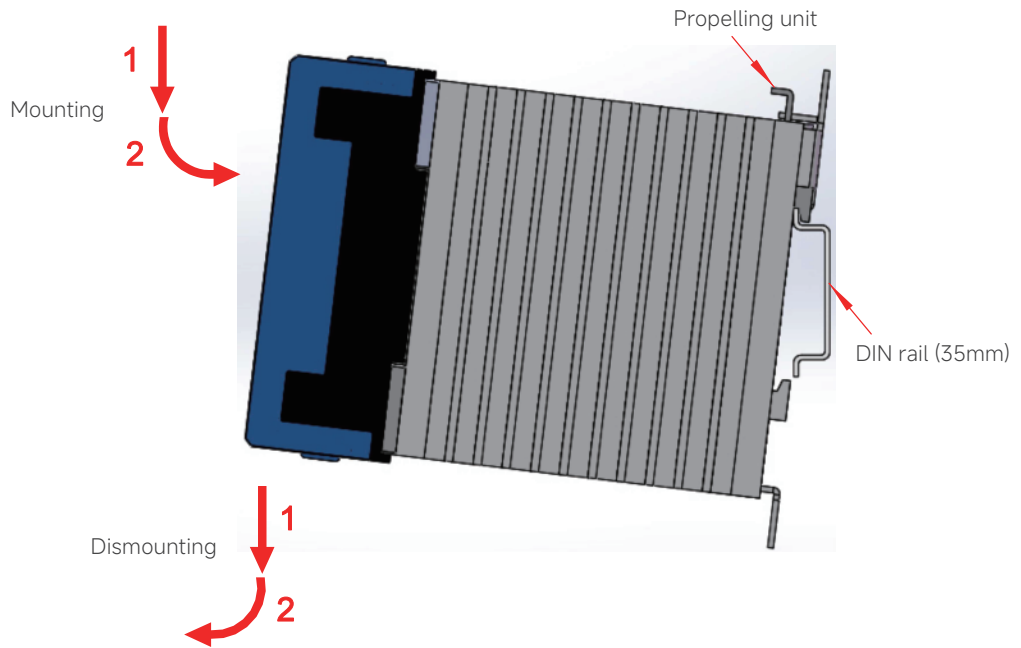

Thermal Derating Curve

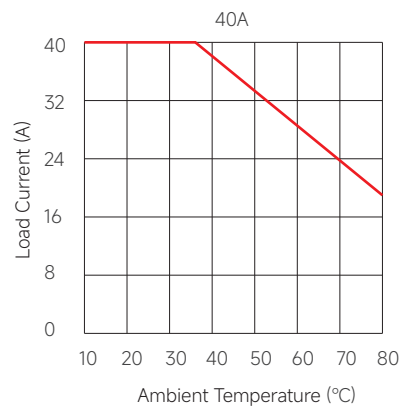
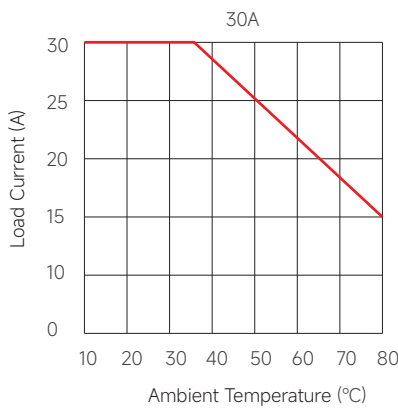
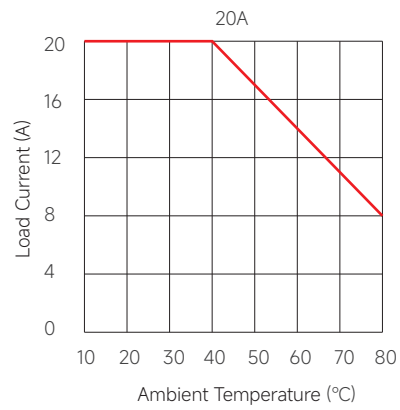
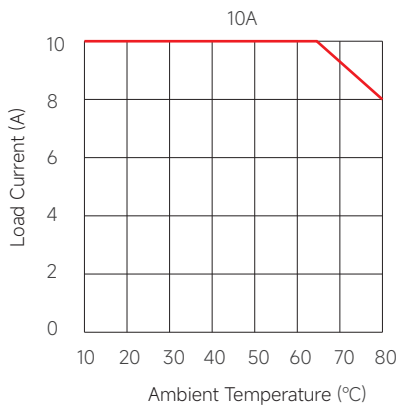

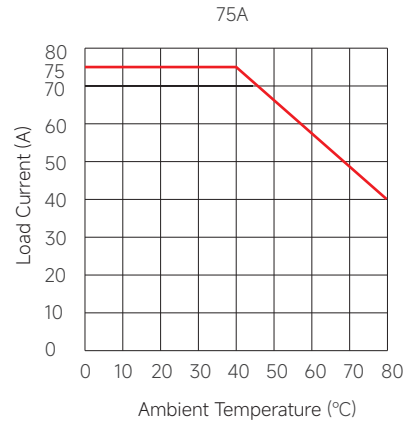
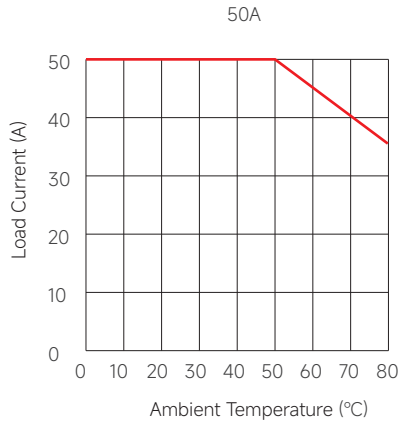

Note: The curve above shows the heatsink capability under the worst case (100% continuous operation) for a solid state relay. If your application involves intermittent operation, please contact us with your actual operating conditions (load current, on/off time, ambient temperature, etc.), and we will recommend the most suitable solution for you.

General Notes

- SSR's carrying load capacity is related to the operation ambient temperature and heat dissipation condition, when there are many pieces SSR installed closely, please refer to the Thermal Derating Curve for derating.
- When connection wiring to SSR, please ensure screws are torqued down properly. Please refer to the torque requirement as below.

		Input Terminal (3, 4)	Load Terminal (1, 2)
Recommended Torque		0.6N·m	1N·m
Stripping Length		7mm	10mm
Optional Wire	Single Core Cable	1x0.5~2.5mm ² 2x0.5~1mm ²	2x1.5~6mm ²
	Multi-core Cable (with ferrule)	1x0.5~2.5mm ² 2x0.5~1mm ²	1x1.5~10mm ² 2x1.5~6mm ²

! Warnings

- The product and heatsink may be hot, allow the product to cool before touching.
- Disconnect all power before installing or working with this equipment.
- Verify all connections and replace all covers before turning on power

Certification Standards

Certification	Test Standard
UL	UL508
CE	EN 60947-5-1:2017
	EN IEC 60947-1:2021
	EN 60947-4-3:2014